

Boxfish ROV

ROV Summary

- **Unsurpassed image quality:** The only ROV with uncompressed near-zero latency 4K UHD video and Photo Mode for 20MP RAW and JPG stills
- **High capacity battery:** Up to fifteen hours runtime with optional one hour recharge or hot swap
- **Eight powerful thrusters:** 3D vectored propulsion system for unmatched control in heavy currents
- **Fly-by-wire control:** Position ROV at any angle, even in current
- **Three cameras:** Main 4K camera plus front and rear 180° navigation cameras ensure exceptional situational awareness
- **Thin tether to 3km+ (2mi+):** Low drag ultra-light 2.7mm (0.11in) fibre-optic tether, which is virtually indestructible (Optional 4.3mm)
- **500/1000m (1640/3300ft) depth:** Proven, rugged and upgradable design you can count on no matter how deep or shallow you are going
- **Light and portable:** Air travel friendly, 24kg (53lbs)
- **Made to last:** Hard anodised aluminium, user-replaceable parts, fault-tolerant design
- **Ultra-bright lights:** Dual dimmable 8,500-lumen lights upgradable to 17,000 lumens for better vision.



BOXFISH[®]
R E S E A R C H

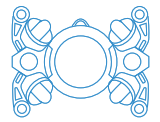

Observation Class ROV

The Boxfish ROV is an industry-leading observation class ROV that delivers 4K live video from depths of up to 1000m over its lightweight neutrally-buoyant low drag fibre optic tether.

Although the Boxfish ROV is a portable, lightweight system able to be lifted and deployed by a crew of two (24 kg), it is capable of operation and precise positioning in heavy currents thanks to a patented active stabilisation system. With batteries onboard, the ROV can hover up to 15 hours underwater at a time.

The Boxfish ROV has a flexible, modular design allowing for a payload of additional sensors and accessories. The Boxfish ROV platform can be integrated with a range of accessories including grabbers, manipulators, altimeter, USBL, laser scaler, and much more. Multibeam imaging sonar, profiling sonar and stereo cameras can be configured to allow detailed imaging and 3D mapping.

The complete package comes in three easily portable hard cases for tether, ROV and surface control/accessories, and is able to be deployed in minutes from any vessel and repackaged for further travel.

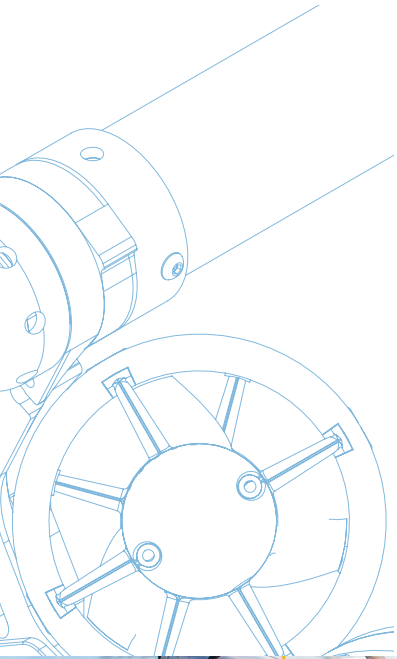

“ While we had an idea of what might lay beneath the surface, due to published data, Boxfish was able to confirm the environment at 710 meters depth for us! ”

Nigel Ironside, Senior Environmental Advisor, POAL



Technical Specifications



Accessory rail system

2 x 460mm length parallel (top, bottom) 8mm diameter, 52mm spacing (centre to centre)

Pressure vessel

Material: Hard anodised aluminium alloy

Dome

Material: Acrylic

Thruster layout

8 vectored

Surface Control Station

- 17" 4K UHD main display
- Camera zoom control
- Three joysticks for easy control
- Weatherproof design

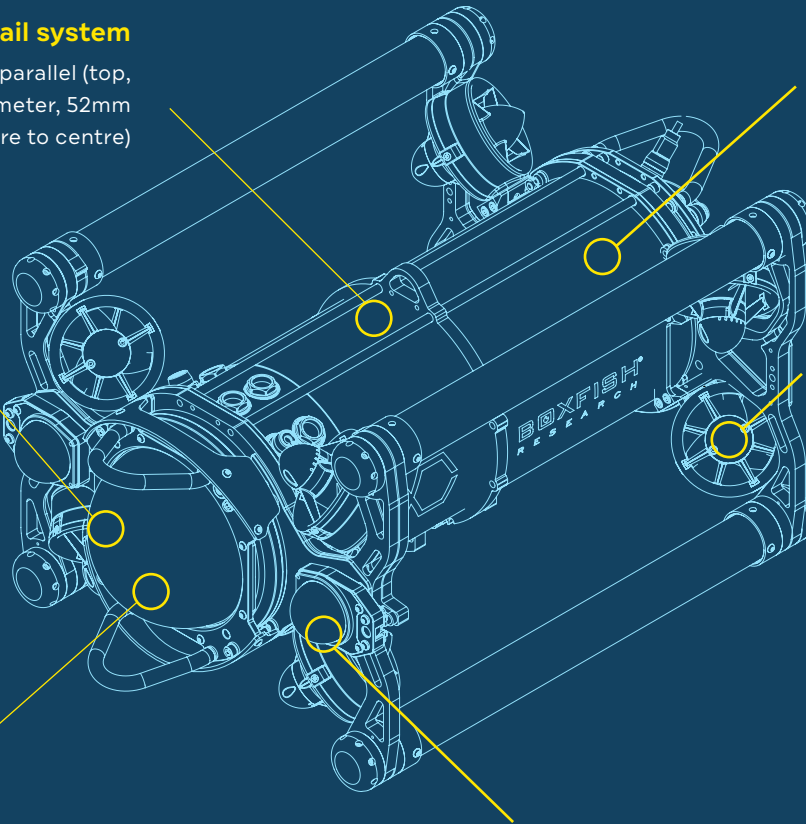

Main 4K camera

- 4K 30p live uncompressed 8-bit video recorded at the surface
- 20MP RAW and JPG stills
- Large 1" sensor
- 16-48mm equiv. f/1.8 - f/2.8 lens: 6x zoom capable
- Zoom control
- Focus control (automatic and push-to focus)

Integrated sensors

- Depth
- Internal humidity
- Battery and supply voltages
- Thruster telemetry
- 9-axis IMU
- Leak detection
- Compass

Lighting

- Forward option: 2 x 8,500 lumen, high CRI, dimmable
- Adjustable arms and ball mounts for excellent lighting in all orientations
- Reverse lights
- Additional forward lighting options available

Navigation cameras

- 1 x forward FHD, 180 degree horizontal view
- 1 x reverse FHD, 180 degree horizontal view

ROV

Depth rating

500m (1,640ft); optional 1000m (3,300ft)

Dimensions

(l/w/h): 714mm (28in)/ 435mm (17in)/ 351mm (14in)

Weight in air salt water

ballast: 24kg (53lbs); fresh water ballast: 23kg (51lbs)

Operating temperature

-10°C (14°F) to +45°C (113°F)

Battery capacity

600 Wh battery endurance: 4-15 hrs (condition dependant)

Battery recharge time

6 hours AC (typical). Fast 1 hour charge option.

Power to external connections

12V (50W) or 24V (50W)

Standard external connections

Boxfish tether connector

Boxfish charge connectors

External sensor integration

Up to eight Boxfish standard ports (other options available)

Data

RS232, RS422, RS485 and Ethernet (10/100/1000mbps)

Tether

Type: Fibre optic with synthetic strength members

Buoyancy: Neutral in salt water

Weight

6kg per 1000m for 2.7mm diameter

Length options

200m (656ft); optional 3,000m+ (10,000ft+)

Diameter

2.7mm (0.11in) optional 4.3mm

Breaking strength

110kg for 2.7mm or 525kg for 4.3mm

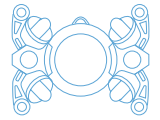

Features and Benefits

Industry Leading Design

The Boxfish ROV's lightweight design offers easy deployment and operation with a crew of just two from virtually any small boat without the need for further equipment. At just 24kg, it is easy to launch and recover by hand and operate down to 500m with options to go to 1000m.

Built in ultra wide-angle navigation cameras offer unprecedented surround visibility and give the pilot excellent situational awareness. This coupled with the auto-stabilisation system and pilot assist makes piloting the ROV a breeze. Should disaster strike, the ROV will automatically return to surface under its own power.

Surface Monitoring and Controls

Live uncompressed 4KP30 video is displayed in real-time on a stunning 17" 4K monitor, while navigation cameras and telemetry are shown on a second, super-bright 10" monitor. A multitude of inputs and outputs cater for the addition of external video recorders, USBL (underwater GPS) systems, sonar and other accessories. The intuitive layout allows even a novice to learn the controls quickly.

Tether

Our ultra light weight, neutrally buoyant 2.7mm diameter, fibre optic tether is extremely robust. It offers very low drag and easy handling on deck and in the water. A 4.3mm tether diameter is available, and a range of tether lengths on a quick change spool, allowing easy replacement or changeover.

Maneuverability

With eight 3D vectored thrusters, the Boxfish ROV offers the unique capability of true six degrees of freedom of movement. The vehicle can travel and orientate itself in any direction giving the user a powerful tool for getting into, and working in, tight spaces not accessible or visible with conventional ROVs.

Lighting

A pair of LED lights (with 8,500 lumens each) offer outstanding illumination for inspection in total darkness. The high CRI (>90) and adjustable ball mount arms, give optimal lighting for the best possible image capture.

Fast Charge

Battery charge options, rapid one hour charge and standalone power are available. The Boxfish ROV can be fully recharged in five hours using the standard AC charger. Quick access sealed ports mean the ROV can be charged easily and quickly in the field.

Serviceability

The Boxfish ROV is low maintenance. Any of the eight thrusters can be replaced in minutes with basic tools allowing you to keep working longer.

Payload

A wide range add on sensors can be attached via Ethernet or RS-422, RS-232 or RS-485 with a number of expansion ports available on the hull.

Optional Capabilities

- Multibeam imaging sonar
- Manipulator/grabber
- Altimeter
- USBL (Underwater Positioning System)
- Laser scalers
- Brush and more.

Contact our Sales team for further details.

Boxfish ROV is designed for

submerged asset inspection, biosecurity search & rescue, marine science, research vessels, offshore energy, aquaculture and cinematography.