

Boxfish

LUNA

Owner's Manual

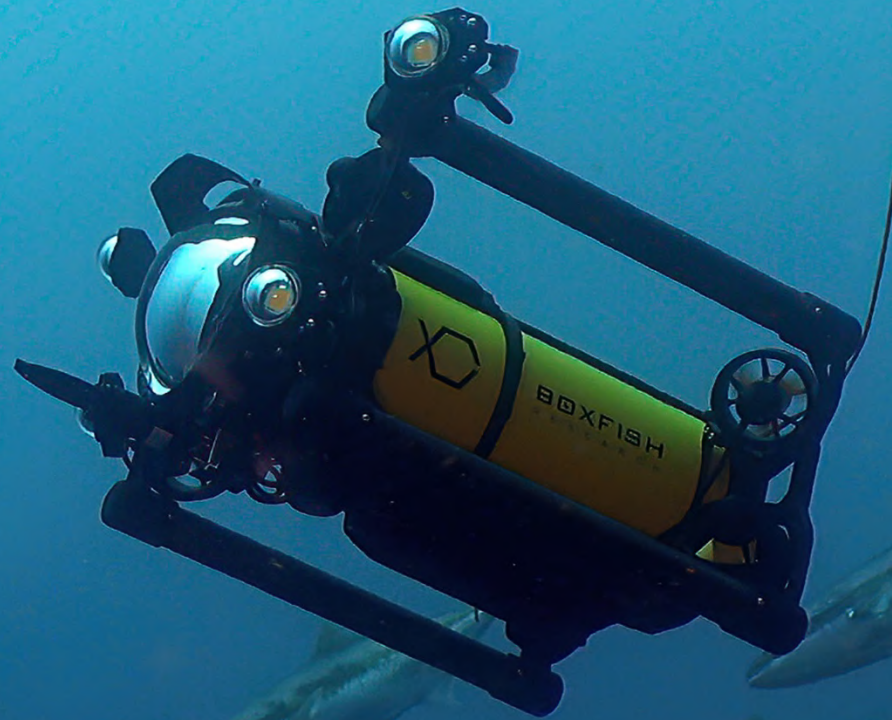

BOXFISH[®]
RESEARCH





Table of Contents

1	Welcome to Boxfish.....	7
2	Notices	8
3	About this document.....	9
3.1	Other Luna documents	9
3.2	IMPORTANT and WARNING messages	9
4	Important safety information.....	11
4.1	Battery safety, maintenance, storage and disposal	11
4.2	Lifting ROV components	11
4.3	Hazards.....	11
4.4	Safe ROV operation.....	12
5	Boxfish Luna ROV system overview.....	13
5.1	Storage cases.....	13
5.2	ROV.....	14
5.3	Control Station.....	16
5.4	Tether.....	20
5.5	Accessory Box contents.....	21
6	Charging the ROV battery pack.....	27
6.1	Receiving your ROV	27
6.2	How to charge your ROV battery pack.....	27
7	Putting together the Boxfish Luna system.....	28
7.1	Connecting cables - connection diagram.....	28
7.2	Connect Control Station to power	29
7.3	Assemble tether reel.....	29
7.4	Connect fibre patch cable to tether reel and Control Station.....	30
7.5	Connect tether cable to ROV	31
7.6	Storing tether penetrator cap and fibre caps during your dive.....	32
7.7	Attach Ninja V monitor/recorder to Control Station.....	32
7.8	Familiarity with your ROV.....	33
8	Powering on the Boxfish Luna	35
8.1	Power on Control Station.....	35
8.2	Power on ROV with magnetic key	35
8.3	View feeds on telemetry screen.....	35
9	Pre-deployment checks.....	38



9.1	Camera setup and testing.....	38
9.2	Apply and test vacuum on ROV pressure vessel.....	38
9.3	Test LED illumination lights	40
9.4	Inspect and test thrusters.....	40
9.5	Test scaling lasers (if present)	41
9.6	Lubricate tether penetrator O-rings.....	41
9.7	Test external devices and Luna configurations	42
9.8	Practise adding ballast washers (and ballast bars, if present)	42
10	Boxfish Luna pack up sequence (from out-of-water testing)	43
10.1	Power off Ninja V Recorder	43
10.2	Power down ROV	43
10.3	Power down Control Station	43
10.4	Unplug tether from ROV.....	43
10.5	Disconnect fibre patch cable	44
10.6	Pack away other components	44
11	Planning your dive.....	45
11.1	Charge ROV Battery	45
11.2	Safety	45
11.3	Research your launch vessel/site	45
11.4	Depth rating of your ROV and external devices	46
11.5	Hazards.....	46
11.6	Keeping the ROV cool	47
12	Deploying your Boxfish Luna in the water	48
12.1	Overview	48
12.2	Assembling Boxfish Luna for a dive.....	48
12.3	Power on ROV and Control Station	48
12.4	Pre-deployment checks.....	48
12.5	(If installed) Turn on Sensor Power switch for external devices.....	48
12.6	Put ROV in the water	49
12.7	How to balance your ROV and make it neutrally buoyant.....	49
12.8	Check depth sensor	50
12.9	Begin launch sequence	50
13	Piloting your ROV.....	52
13.1	Useful telemetry screen info for piloting	52
13.2	Moving the ROV	53
13.3	Piloting modes	54



13.4	Sea Modes.....	54
13.5	ROV Modes.....	54
13.6	Controls for Sea Mode and ROV Mode (non-Q modes).....	55
13.7	Controls for Quad Modes (Sea-Q Mode and ROV-Q Mode).....	57
13.8	Speed.....	57
13.9	Depth Hold.....	57
13.10	Heading Hold.....	57
13.11	Altitude Hold.....	58
13.12	Using the LEVEL button.....	58
13.13	Adjusting the ROV LED illumination lights.....	58
13.14	RTS (Return to Surface).....	58
13.15	When to disable RTS (Return to Surface).....	59
13.16	Battery monitoring during your dive.....	59
13.17	Battery limits.....	59
13.18	Piloting tips and tricks.....	60
13.19	Notes.....	60
14	Managing tether cable during a dive.....	61
14.1	Safety.....	61
14.2	Avoiding snags, knotting of tether.....	61
14.3	Avoid pulling on tether while ROV is filming.....	61
14.4	Tips.....	62
15	ROV surfacing and retrieval.....	63
15.1	How to bring ROV back to surface.....	63
15.2	Removing the ROV from the water.....	63
15.3	Power down ROV.....	63
16	After-dive procedures.....	64
16.1	Disconnect ROV components and cables.....	64
16.2	Rinse ROV, tether, and any accessories.....	64
16.3	Leave ROV components to dry.....	64
16.4	Attend to ROV battery.....	65
17	Storing your ROV.....	66
17.1	Prepare for storage.....	66
17.2	Storage conditions.....	66
17.3	Adjust battery to storage voltage.....	66
17.4	Monthly maintenance during storage.....	66
18	Updating your Luna system.....	68



18.1	Items required	68
18.2	Relevant buttons and labels	68
18.3	How to update Luna Control Station and camera	68
18.4	How to update ROV	69
19	Troubleshooting	70
19.1	Potential issues and solutions	70
19.2	How to recalibrate ROV compass	73
19.3	How to retrieve log files from Control Station	75
19.4	Thruster troubleshooting	75
19.5	Clear camera settings screen from main Control Station screen.....	76
20	Regular maintenance procedures.....	77
20.1	Monthly maintenance charging	77
20.2	Dome care and maintenance	77
20.3	Tether care	77
20.4	As required: cleaning the fibre optic connections	77
20.5	O-rings maintenance	80
21	Authorised repairs	82
21.1	How to release vacuum from inside the ROV	82
21.2	How to replace a thruster	82
21.3	How to replace a propeller.....	84
21.4	How to put a thruster back on the ROV	87
21.5	ROV LED lights replacement procedure	88
21.6	Tools required	88
21.7	Changing time zone on Control Station	92
22	Shipping or travelling with the ROV	94
22.1	Returning your ROV to us for service or repair.....	94
22.2	General preparation	94
22.3	Preparing ROV battery pack	94
22.4	Packing the ROV components.....	95
22.5	Meeting weight limits for air travel.....	95
23	Appendix I: Control Station – more information	97
24	Appendix II: Telemetry screen – more information	104
25	Appendix III: Boxfish Luna ROV – more information	106
25.1	Status indicator LEDs	107
26	Document history.....	109





1 Welcome to Boxfish

Congratulations on your Boxfish Luna! Please read these instructions carefully before use.

The Boxfish Luna is an ROV with an advanced camera (Sony a7S III or Alpha 1) with multiple recording options and surface camera controls, allowing you to capture cinematic-quality underwater video and still images.

In this manual, and the accompanying **Boxfish Luna Camera Operations Manual** and **Boxfish Battery Charging Manual**, we aim to give you easy to follow instructions for using your Boxfish Luna.

If you need help using your Boxfish Luna, please contact us at support@boxfish.nz.

We hope you enjoy your Boxfish Luna!



2 Notices

This manual is part of the documentation for your Boxfish product as mentioned in our Terms of Sale (available on our website at <https://www.boxfish.nz/support/terms-conditions/>).

Please ensure all Boxfish Luna operators have read and understood this manual and accompanying **Boxfish Luna Camera Operations Manual** and **Boxfish Battery Charging Manual** before using your Boxfish Luna.

We make every effort to ensure that the information in this manual is an accurate and complete description of this Boxfish product at the time of release of this manual.

The latest version of this manual will be available to all customers on our website at <https://www.boxfish.nz/downloads/>. The most recent version on our website will supersede any previous versions, whether printed or electronic.

We will not be held responsible for any errors or omissions from this manual, and we reserve the right to change the specifications of the hardware and software described in this manual at any time and without prior notice.

We will not be held liable for any damages resulting from the use of this product.



3 About this document

When first using your Boxfish Luna ROV, we recommend reading this document from beginning to end. Once you are familiar with your ROV, you can use it as a reference or to refresh your memory.

This document covers:

- General safety information
- Components of the ROV system
- How-to guides for ROV operations, including testing and field use
- Tips and tricks to get the best out of your ROV
- Storage instructions
- Approved maintenance instructions
- Guidelines for packing, travelling with and shipping the ROV
- Troubleshooting tips.

3.1 Other Luna documents

3.1.1 Battery safety information and instructions

This document does NOT cover any instructions or safety information relating to the Lithium Polymer (LiPo) batteries used in your ROV battery pack. For this information you must read our **Boxfish Battery Charging Manual**. (latest version available on our website: <https://www.boxfish.nz/downloads/>).

3.1.2 Shooting with the Boxfish Luna

This document does not describe how to take video or still images with the Luna. We have created a separate manual, the **Boxfish Luna Camera Operations Manual** with all information related to shooting video and photos.

3.2 IMPORTANT and WARNING messages

Throughout this document you will see the following messages:

IMPORTANT!

Important notices draw your attention to things you must do (or must not do) so that you don't **BREAK OR DAMAGE** the ROV or its accessories.



WARNING!

Warnings are for your **SAFETY** so that you don't **CAUSE INJURY** to yourself, any other operators of the ROV, or people nearby.



LiPo BATTERY WARNING!

Warnings for **SAFETY** so that **INJURY** or **DAMAGE** does not occur when dealing with the **Lithium Polymer (LiPo)** batteries in **Boxfish ROV battery packs**.

If not treated according to our instructions, **LiPo batteries** could leak **corrosive substances**, emit **toxic gases**, catch fire or **explode**.



4 Important safety information

Please follow the information in this section closely to prevent injury, damage, or violation of your warranty conditions (available in our Terms of Sale at <https://www.boxfish.nz/support/terms-conditions/>).

4.1 Battery safety, maintenance, storage and disposal

The ROV contains Lithium Polymer (LiPo) batteries in its battery pack.

Please refer to our **Boxfish Battery Charging Manual**. (latest version available on our website: <https://www.boxfish.nz/downloads/>).



LiPo BATTERY WARNING!

You must read the Boxfish Battery Charging Manual and follow the instructions carefully. Misuse of the Boxfish ROV lithium battery pack may cause a battery fire and/or explosion.

4.2 Lifting ROV components

- The ROV, Accessories Box (with Control Station inside) and larger tether reels (>1.2km version) require two people to lift. Take care when lifting.
- The ROV can only be safely lifted by the stainless-steel bumper/protection bars, carbon fibre frame tubes, or the lifting eye on top.



4.3 Hazards

- Take extreme care around deep water and potential slip hazards when piloting and retrieving the ROV.
- Plan your operations to minimize trip hazards from the ROV system, especially the tether and cables.



- Never operate the ROV in the presence of unaware swimmers or other vessels.
- Supervise children and keep them well away when ROV is operating.
- While ROV is running pay close attention to the thrusters. Do not touch the thrusters any time the ROV is powered on, or serious injury may occur. Keep fingers, long hair and loose clothing or anything that may become entangled well clear of the thrusters when operating.
- The ROV should not be operated close to any object which may get caught in the thrusters.
- DO NOT look directly into the ROV LED illumination lights when they are turned on.
- DO NOT look directly into the ROV scaling lasers (if supplied). The scaling lasers emit Class 3R laser light. Laser protective eye wear is normally not necessary. A Class 3R laser is not a skin or materials burn hazard.



- DO NOT look directly into fibre optic cables, or fibre optic ports on the ROV, tether reel or Control Station while the ROV or Control Station is operating. The lasers used to transmit the signal is invisible but can cause damage to the retina of the eye. The below stickers are present on these ports to remind you.



4.4 Safe ROV operation

- The Boxfish Luna takes **at least two** people to operate: one person to pilot the ROV and one person to manage the tether cable.
- DO NOT use the ROV below its depth rating: check the rating specified in your order or contact us if you are unsure. Some domes have different depth ratings to the ROV – check with us if you are unsure.
- DO NOT operate in currents where control is impeded.
- DO NOT operate outside the water temperature range of -10°C to $+45^{\circ}\text{C}$.
- DO NOT store the ROV outside the range of -20°C to $+70^{\circ}\text{C}$.

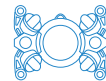

5 Boxfish Luna ROV system overview

5.1 Storage cases

Each component of your Boxfish Luna system will be stored in a black waterproof Pelican case. A typical Luna system is shown below.



ROV case (left)	ROV case. Includes the Boxfish Luna ROV.
Tether case (middle)	Includes tether reel and cable. Winder handle and thumbscrew to attach the handle are also in this case.
Accessory Box (right)	Contains: <ul style="list-style-type: none">■ The surface Control Station in its own case.■ All necessary cables, tools and spare parts for your ROV.

There may be additional cases if you have ordered extra sensors, domes or other accessories.

IMPORTANT! The Control Station must be stored inside the Accessory Box case for protection.



5.2 ROV

Note: Individual Boxfish Luna ROVs may vary from the below specifications.



Front and left side view

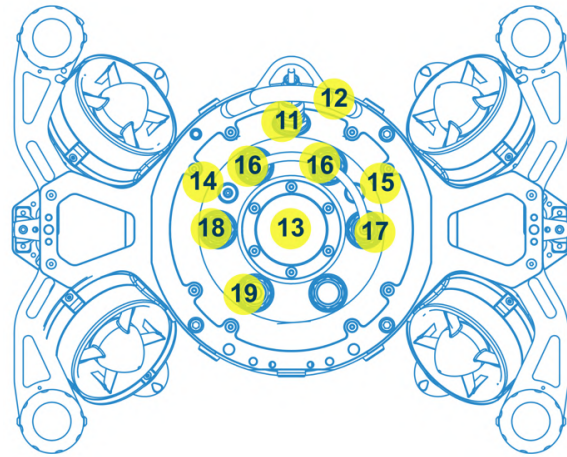

Rear view

1.	Pressure vessel	Pressure-rated ROV body with ports for thrusters, lights and external accessories as ordered. Depth rating of your vehicle (excluding any external accessories) is dependent on this component. Please check your order for your vehicle's depth rating.
2.	Front dome or flat port (depending on order) *	Inside the dome, the camera assembly contains the Sony a7S III or Sony Alpha 1 front camera and wide-angle navigation camera. A Perspex dome protector will be clipped onto the dome exterior for travel and testing
3.	Sunshade/bumper	Black Perspex sunshade/bumpers to protect dome
3.	Luna front ballast system	(Some Lunas only) Ballast weights may be present above and/or below the front dome
4.	Frame tube/lifting tube	Carbon-fibre shock-absorbing buoyancy tubes with balancing chambers at each end
5.	Ballast chambers	Chambers for ballast rings
6.	Thrusters	Eight 3D vectored thrusters
7.	Lifting eye	For attachment of a lifting or securing cable
8.	Lighting arms and LED lights	Adjustable arms with LED illumination lights



9.	(Optional)	Adjustable second set of LED illumination lights (optional extra)
10.	Rails for optional accessories	For mounting external accessories such as sonar or USBL
11.	Tether port	To connect fibre optic tether cable
12.	Rear bumper	Stainless steel protective bumper
13.	Rear dome	Contains Status LEDs, rear navigation camera, rear navigation LEDs
14.	Off pad (red)	For powering off ROV using magnetic key
15.	On pad (green)	For powering on ROV using magnetic key
16.	Battery charge ports	Positive and negative ports (terminals) for battery charging
17.	Battery balance port	For connecting cell balancing cable to charge each battery cell to the same voltage
18.	Vacuum port	Port for applying vacuum to ROV body
19.	Depth sensor	Port containing ROV depth sensor

* Notes:

- Glass domes: if you have ordered a larger glass dome, the dome will not be fixed to the ROV during shipping as it does not fit inside the ROV case. A cap (or standard dome or flat port, if ordered) will be affixed to the front of the Luna to protect internal components during shipping, and the glass dome will be shipped in its own case.
- Dome protectors: ROVs shipped from mid-2022 onwards have a black plastic protector on the front dome. It is a good idea to leave this in place as often as possible to keep the dome free of scratches.

5.2.1 Front camera

With the Boxfish Luna ROV there are two options for the front camera: the **Sony a7S III** and **Sony Alpha 1**.

An easy-to-use mounting system inside the ROV makes it easy to change lenses (if supplied), adjust physical dials on the camera and even swap between cameras (if both cameras are ordered).

Please see the separate **Boxfish Luna Camera Operations Manual** for details on how to use the camera.



5.3 Control Station

The Control Station is a multifunctional surface unit. It is used to:

- Receive and display video and telemetry data from the ROV
- Pilot the ROV
- Remotely operate the front camera inside the ROV and facilitate recording of photos and video (via Ninja or on-camera)
- Plug in optional accessories or connect a computer
- Update software and firmware for the ROV, Control Station and camera operation system
- Retrieve logs from the ROV (if needed for troubleshooting purposes).

The Control Station is connected to the ROV via a fibre patch cable. The tether reel in turn is attached to the ROV via the tether cable.

IMPORTANT!

The Control Station is designed to be splash-proof, with seals around all components on the control panel, but it is not waterproof around the air vents. Do not block the air vents otherwise the Control Station could overheat.



5.3.1 Control Station layout

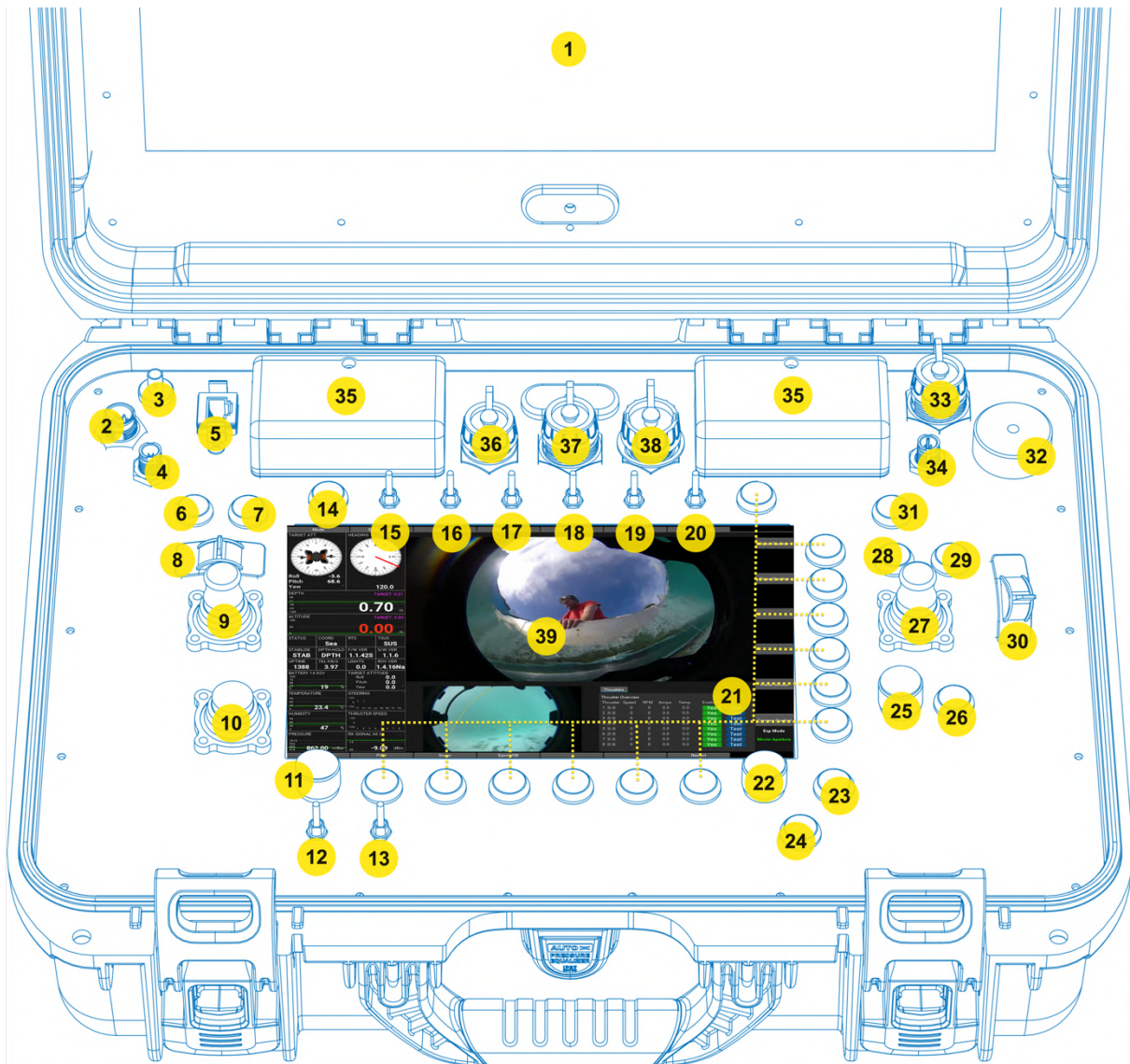

1.	17" 4K monitor. Displays video feed from front camera.
2.	POWER: Power in port. Provides power to the Control Station, via: <ul style="list-style-type: none"> ■ Boxfish AC Adapter (15 Volts 13.4 Amps), OR ■ Directly from a DC supply capable of supplying 10 Amps with the Boxfish DC Power Cable, OR ■ Boxfish DTap power cable.
3.	FIBRE communication port: used to send/receive telemetry, control signals and video between the Control Station and the ROV. Communication is provided by connecting a fibre optic patch cable between the fibre communication port and the tether reel fibre connector and the tether cable to the ROV.



4.	EXT port. Supplies 12V and can be used to power the local USBL beacon (if USBL accessory is supplied). See USBL manual.
5.	ETHERNET: RJ45 network port. Can be used to connect a laptop/computer to the Control Station and access data from certain sensors (eg sonar).
6.	LEVEL button. Can restore the ROV to zero roll and pitch, or reset control inputs, see Piloting section.
7.	ENABLE button (green). Used to power on Control Station, and to enable the thrusters during the launch sequence
8.	THRUST control thumb wheel. Used to adjust speed of the ROV through the water
9.	LEFT joystick. In Sea Modes, used to control the ROV Depth and Lateral movements. In ROV Modes, used to control the ROV Depth and Yaw movements.
10.	AUX joystick. Controls pitch and roll ROV movements
11.	Dial for adjusting intensity of LED illumination lights
12.	LIGHTS switch. Turns on and off LED illumination lights
13.	LASERS switch. Turns on and off scaling lasers (if present)
14.	Mode button. For selecting ROV operational mode: Sea Mode, Sea-Q Mode, ROV Mode or ROV-Q Mode. Also used to recalibrate compass
15.	Stabilisation Hold switch. To enable/disable Stabilisation Hold function. Also used to switch between compass and gyro, and activate Heading Hold
16.	Depth Hold switch. To enable/disable Depth Hold function. Also used to activate position hold if DVL is present
17.	Sensor Power on/off switch. Used to supply power to additional sensors or accessories (if present on your ROV). Use only as directed in the applicable manual for the sensor/accessory
18.	RTS Disable switch (Return to Surface Disable) to enable/disable automatic return to surface functionality. Usage detailed in Piloting section
19.	Manual Focus on/off switch. To toggle focus mode of front camera between Auto Focus and Manual Focus
20.	Altitude Hold on/off switch (can only be used if optional altimeter or DVL accessory is present)
21.	Multi-functional buttons. Usage will be described in applicable chapter in this manual or accessory manual



22.	Dial to scroll through available settings for the front camera on the Camera Control GUI (see Boxfish Luna Camera Operations Manual)
23.	OK button (✓). Used for thruster test or to select a setting for the front camera using the camera application
24.	Cancel button (X). Not used in normal operations
25.	Zoom dial to adjust zoom on front camera. Turn slowly for best results
26.	FOCUS button. When camera is in Manual Focus mode (ie Manual Focus switch is in the ON position), can push and hold this button to focus the camera
27.	RIGHT joystick. In Sea Modes, used to control the ROV forward, back and yaw movements. In ROV Modes, used to control the ROV forward, back and lateral movements.
28.	PHOTO button. Used to change front camera to photo mode, and to take a photo with the front camera - see Boxfish Luna Camera Operations Manual.
29.	VIDEO button. Used to start/stop recording video on the Luna camera. Can also be used to restart camera control system. See Boxfish Luna Camera Operations Manual.
30.	(Optional: only present if ordered) ZOOM/FN thumb wheel. Used to quickly adjust camera's aperture and ISO settings
31.	STOP button (red). Used to disarm the thrusters (short press) or power off the Control Station (six second press)
32.	¼" mounting plate. Used to attach the mount for the Ninja V recorder
33.	ACCESSORY port. To connect power cable for the Ninja V
34.	CLEAN HDMI port. Used to route the HDMI output from the front camera into the Ninja Recorder
34.	Air ventilation intakes. Used to keep Control Station cool. Do not cover or allow water to enter
36.	Left USB port. Can be used for software updates, uploading log files, and attaching accessories (usage will be detailed in accessory manual). For Lunas with Alpha 1 cameras, can also be used to download files recorded on-camera (see Boxfish Luna Camera Operations Manual)
37.	HDMI In port. Used to output HDMI signal from the Ninja to the 17" 4K screen. See Boxfish Luna Camera Operations Manual
38.	Right USB port. Can be used for attaching accessories (usage will be detailed in accessory manual)



39.	Telemetry screen. Displays data and navigation video from the ROV to assist in piloting
-----	---

More information and specifications of the Control Station is in [Appendix I: Control Station - more information](#). Camera-related controls and functionality are explained in the **Boxfish Luna Camera Operations Manual**.

5.4 Tether

IMPORTANT!

Do not drop the tether penetrator. Parts used in the termination inside the tether penetrator can be easily damaged by drops or knocks.

The tether reel comes in a few standard sizes and lengths depending on the depth capability of your ROV. The parts shown below are common to all sizes. The **tether penetrator** (at the end of the fibre optic tether cable) attaches to the ROV. The tether reel connects to the Control Station via a **fibre patch cable**, which is attached to the side of the tether reel.

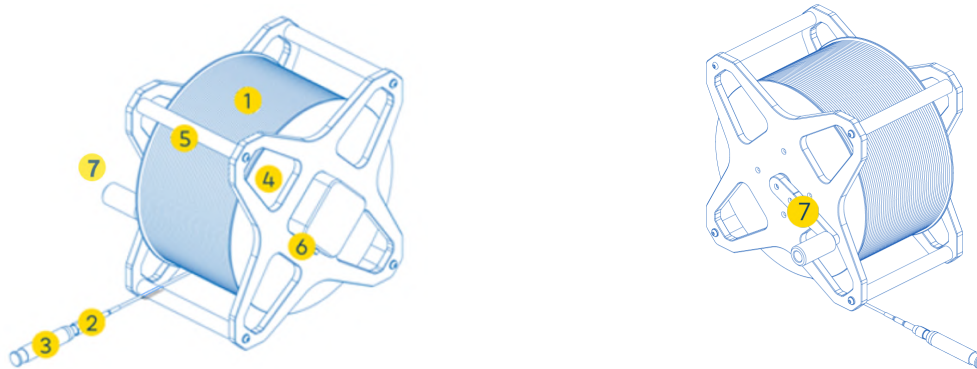

1.	Tether cable (fibre optic)	Durable fibre optic cable. Neutrally buoyant in salt water. Carries all control, telemetry and video signals to and from the ROV. Comes in 2.7mm, 3.7mm or 4.3mm standard diameters.
2.	Tether penetrator and protective caps	This is the brass connector containing the fibre cable at the end of the tether cable. The tether penetrator connects to tether port on the ROV. When not in use:
3.		



		<ul style="list-style-type: none"> ■ The tether penetrator should always be covered with TWO caps: a small plastic dust cap should cover the exposed end of the fibre cable, and the large black plastic cap should cover the whole brass assembly. Additionally, the black plastic cap should be fastened to its black plastic collar on the tether cable. ■ The tether penetrator assembly should be secured to the tether reel with a Velcro strip so it does not get damaged inside the tether case.
4.	Drum	Stores the wound tether cable. Light tension should be applied to the tether cable while winding onto the drum to prevent knots and kinks in the cable.
5.	Carry handles	Used to carry and move the tether reel, and to secure the tether penetrator with Velcro when not in use.
6.	Fibre patch cable port	Port for the fibre optic patch cable between the tether reel and the Control Station. Always cover the connector with its red/yellow cap when not in use.
7.	Tether reel winder handle and thumbscrew	Used to wind the tether cable back onto the drum. The handle should be attached to the tether reel using the thumbscrew provided. Not for use as a winch: do not use winder to retrieve ROV using the tether cable.

5.5 Accessory Box contents

The following items are provided in the Accessory Box at the time of this manual's release. Other items may be present depending on your order.

5.5.1 Camera peripherals

Items for your Boxfish Luna front camera (Alpha 1 or A7S III), including:

- Spare lens(es) (if purchased)
- Lens caps: for camera and for any spare lenses
- Battery charger and a spare battery.



5.5.2 Control Station power cables

Power can be supplied to the Control Station via one of the options below:

- AC outlet, or
- D-Tap, or



- 12V DC source such as boat or car.

	<p>Universal single-phase (100-250V AC 50-60 Hz) AC adaptor for powering the Control Station from an AC supply.</p> <p>Local cable to connect the AC power adapter to your local wall outlet.</p>
	<p>Standard vehicle type plug for powering the Control Station from a DC supply.</p>
	<p>Cable to power Control Station from an external battery with a D-Tap connector.</p>



WARNING!

ONLY use AC power adapters supplied by Boxfish.

DO NOT connect the Control Station to a DC supply less than 10.5V or greater than 29.5V.

5.5.3 Fibre patch connector cable

Armoured, military grade fibre patch cable. This cable connects the tether reel to the Control Station. Two cables are supplied with standard orders.

IMPORTANT!

The connectors at each end of the fibre patch cable are covered by clear plastic dust caps to protect the sensitive fibre optics inside. Caps must be in place when not in use to protect fibre optic connections.



*Fibre patch cable. Note the ends are protected with clear plastic caps – **always** keep these on when cable not in use.*

5.5.4 Battery charger and cables

The below items are used to charge the ROV battery pack. Charging is done while the battery pack is inside the ROV. For more information see our **Boxfish Battery Charging Manual**. (latest version available on our website:

<https://www.boxfish.nz/downloads/>.



LiPo BATTERY WARNING!

Treat all charging equipment with care. Contact us immediately if you have any concern about your charging equipment or need a replacement item.



1.	Battery charger	Universal (100-250V AC 50-60 Hz) AC charger used to charge the ROV battery pack or prepare it for storage or shipping.
2.	Battery charger power cable	Used to connect the battery charger to your local AC supply.
3.	ROV battery charging cable	Positive and negative charging cables.
4.	ROV cell balancing cable	Cell balancing cable to ensure cells within the batteries are charged evenly.



5.5.5 Vacuum pump and hose

Used to put a vacuum in the ROV vacuum chamber, as a way of preventing water ingress.

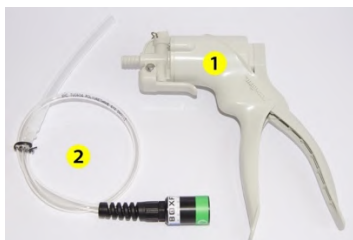

1.	Vacuum pump	Manual hand operated vacuum pump used to apply vacuum to ROV body
2.	Vacuum hose	Connects the vacuum pump to the vacuum port on the ROV

5.5.6 Ninja V 5-inch HDR Monitor Recorder

The Ninja V attaches to the Control Station and records video from the front camera.



	Ninja V monitor/recorder unit *
	Mounting arm: for mounting Ninja to Control Station
	<ul style="list-style-type: none"> ■ Power cable ■ HDMI cables *
	Battery eliminator. Slots into the battery compartment of the Ninja V. Allows cable to be connected to allow power to be provided from the Control Station *
	Atomos SSD Mini. Solid state disk for storing recordings from the Ninja V *

* May not be supplied, depends on your order.



5.5.7 Boxfish SATA to USB Adapter

This device is used to connect the Ninja SSD to a computer to view and download video recorded from the front camera.

	SATA to USB adapter
	USB MicroB to USB Type A cable. Connect USB MicroB end to adapter and USB Type A end to your computer.

5.5.8 ROV magnetic On/Off keys

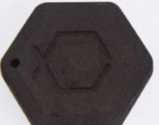
	2x Boxfish magnetic key used for powering the ROV on and off using the off and on pads. Can be attached to a lanyard, key ring or cable.
---	--

5.5.9 Fibre optic cleaning pen and sticks

For cleaning fibre optic connectors on Control Station, tether reel and fibre optic cables.



1.	Fibre optic cleaning pen
2.	Pack containing 10 x single-use fibre optic connector cleaning sticks

5.5.10 Spares and tools







The following spares and tools will be in the Accessory Box.

1.	Set of spare O-rings. See Section 20: Regular maintenance for details
2.	Spare fasteners for rear lid and thrusters
3.	Spare fibre optic caps: 4 x red (or yellow) port caps and 4 x clear plastic dust caps for exposed fibre cable ends
4.	80 x ballast washers (12.5g each) or more if your Luna is light
5.	Silicone grease x 1 tube



6.	Ball-end hex key set
7.	1 x complete thruster set with longer (aft) cable into the ROV
8.	Spare propellers: (CW) and counter clockwise (CCW). 2x M3 x 5 screws are included for each propeller
9.	2x spare HDMI cables for the Ninja V

The following is also supplied in more recent ROVs:

10.	Cable ties: for external cables and batteries in the battery pack.	
11.	Optical fault finder plus 2x AA batteries. Can be used to troubleshoot fibre optic connections.	
12.	L-shaped levers for removing ROV tray.	
13.	USB flash drive 128GB for use with your Luna. See Boxfish Luna Camera Operations Manual for usage.	
14.	HDMI Dongle. See Boxfish Luna Camera Operations Manual for usage.	
15.	Waterproof mouse. Useful for troubleshooting (see Section 19).	
16.	No. 2 Phillips screwdriver (for replacing a thruster or propeller).	
17.	Optical microfibre cloth for cleaning front dome. Note: make sure there are no debris on the dome before using the cloth to prevent scratches.	
18.	Spare weights for front ballast system above/below dome. If this ballast system is present on your Luna, some spare weights and blank spacers will be included in your Accessory Box.	

5.5.11 Optional sensors for the Boxfish ROV system

The accessory box may also contain items for additional sensors in your order. Details will be in the accompanying manual.



6 Charging the ROV battery pack

6.1 Receiving your ROV

IMPORTANT!

After receiving your ROV, ensure its battery pack is charged to storage voltage (15.6V). Do this as soon as you can, especially if your ROV has spent a long time in transit.

6.2 How to charge your ROV battery pack

For all tasks related to battery safety and charging, see our **Boxfish Battery Charging Manual**. (latest version available on our website:

<https://www.boxfish.nz/downloads/>.



LiPo BATTERY WARNING!

You must read the Boxfish Battery Charging Manual and follow the instructions carefully. Misuse of the Boxfish ROV lithium battery pack may cause a battery fire and/or explosion.



7 Putting together the Boxfish Luna system

This section describes how to put together the Boxfish Luna, and how to test some of its functions before you put it in the water.

We recommend finding a suitable place, for example a large table or bench, to practice assembling your ROV for the first time. Caps and covers for the fibre cables and ports are small and may be easily lost. Store these safely and nearby so you can reattach them later.

IMPORTANT!

Do not touch the ends of the fibre cables or fibre ports. Minimise the fibre optic connections' exposure to air, salt, water and dust by removing protective caps immediately before inserting the cables.

IMPORTANT!

Many of the cables and connectors contain exposed pins. You should not need to force any connectors together - doing so will cause breakage. If a cable does not insert first try, look for any guiding grooves or notches, or use a light source such as flashlight or phone light to see the connector better.

7.1 Connecting cables - connection diagram

The diagram below shows how the Boxfish ROV system is connected.

Please read this section carefully as there are special instructions for each connection point.

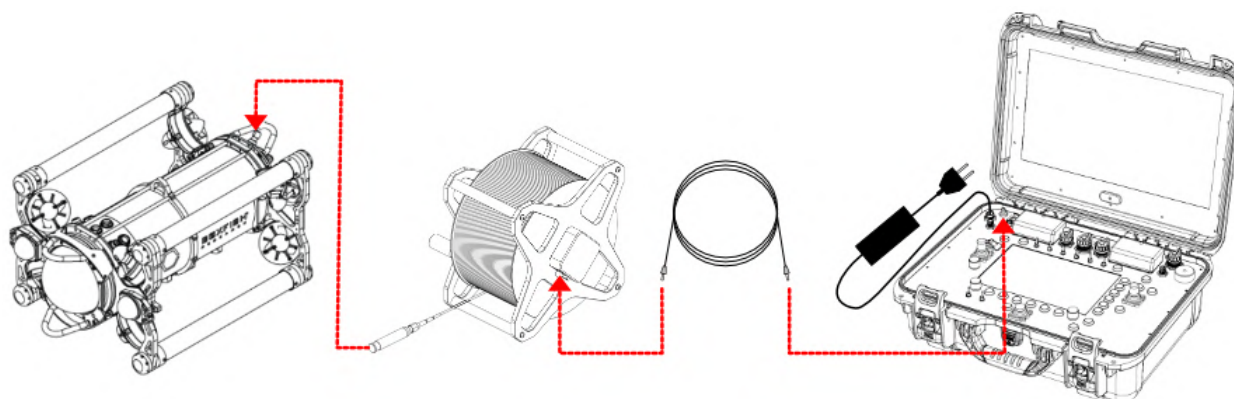

From right to left: Control Station (plugged into a power source) is connected to the tether reel via the fibre patch cable, and the tether reel is connected to the ROV via the tether penetrator at the end of the tether cable.

7.2 Connect Control Station to power

Take Control Station case out of its case. Open the case and remove the cover from the **POWER** port. Connect the power cable to the port: note that the cable and connector have a groove and notch to guide connection. Screw in the cable using the plastic collar to make sure it can't be pulled out accidentally.



Control Station power cable plugged in and secured with plastic collar



WARNING!

ONLY use power adapters supplied by Boxfish.

DO NOT connect the Control Station to a DC supply less than 10.5V or greater than 29.5V.

7.3 Assemble tether reel

Find a place near the Control Station to set up your tether reel.



1. Open the tether reel box. Inside will be the tether reel and handle. The handle will be detached and wrapped for protection.
2. Take out the tether reel and place it so that the rubber feet (to prevent sliding) are on the bottom.
3. Using the provided thumbscrew, attach the handle to the side of the tether reel so that it looks like the picture below.



Handle attached to the side of the tether reel using the thumbscrew

7.4 Connect fibre patch cable to tether reel and Control Station

IMPORTANT!

Do not insert this cable at an angle. It should be inserted perpendicular / straight into the connector to avoid breaking the interior of the connector.

1. Locate the fibre connection port on the side of the tether reel (it will be covered by a red or yellow plastic protective cap).
2. Remove the caps from the port and fibre patch cable. Insert the cable carefully, orienting it perpendicular to the connector. Attach and screw in the cable to the port.
3. Store the caps safely.



Fibre patch connection point on tether reel covered by red cap



Fibre patch cable connected to tether reel

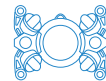

4. Remove the red cap from the **FIBRE** port and remove the clear cap from the cable.
5. Insert the cable carefully, orienting it perpendicular to the connector. Attach and screw in the cable to the port.
6. Store the caps safely.



Fibre patch cable connected and secured to Control Station

7.5 Connect tether cable to ROV

Unwind the tether reel slightly so that the tether penetrator is close to the back end of the ROV. The tether penetrator is shown below.



Tether penetrator (covered by its black plastic protective cap)

Next, practice the below steps so you can perform them quickly and confidently in the field.

1. Unscrew the black knurled collar from the plug in the ROV's tether port (at the rear of the ROV) and pull out the plug. The plug is held in place with two O-rings so you will need to pull past these.



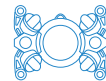

2. On the tether penetrator, unscrew the knurled black collar from the black plastic tether penetrator cap.



3. Take off the tether penetrator cap. The knurled collar will remain on the tether penetrator. The brass tether penetrator will now be exposed. You will see the white inner tether cable which is protected by a clear plastic cap.



4. Remove the clear plastic cap from the end of the fibre optic cable.



5. Insert the tether penetrator into the tether port, far down into the ROV. You will meet some resistance from the waterproofing O-rings. Once the tether penetrator is in position, screw in the black knurled collar so it is finger-tight, as shown in the picture on the right.



7.6 Storing tether penetrator cap and fibre caps during your dive

- Attach the fibre port plug to the tether penetrator cap and Velcro onto the tether reel
- Store the port caps and dust caps in a safe place to reattach after the dive.

7.7 Attach Ninja V monitor/recorder to Control Station

The Ninja can be used to record the HDMI video feed from the front camera. It also outputs the video signal from the ROV to the 17" UHD screen on the Control Station.



For instructions on connecting the Ninja, please see the **Boxfish Luna Camera Operations Manual**.

Note: to bypass the Ninja, attach an HDMI cable from CLEAN HDMI to the centre HDMI screen input on the Control Station.

7.7.1 Recording with the Ninja V

The Ninja has various input and codec options. For more information see the **Boxfish Luna Camera Operations Manual**.

For basic operating instructions see the Ninja V user manual at <https://www.atomos.com/product-support>.

7.7.2 Downloading video to your device

To transfer video recorded on the Ninja V SSD to your device, use the SATA to USB adapter supplied in your Accessories Box.

7.8 Familiarity with your ROV

Now that your Boxfish Luna ROV is put together, note the following items. We will cover these in more details later in this manual.

7.8.1 Thrusters

Check the thrusters and propellers are free of damage/debris before every dive.

7.8.2 Ballast options for buoyancy and balancing

The buoyancy of the ROV will be affected by the following circumstances:

- Changing from fresh water to salt water
- Changing front domes
- Adding or removing external sensors or accessories such as grabbers.

Ballast chambers are located at each end of the frame tubes. Unscrew the caps on the ends of the tubes to access the ballast rings inside.

Your Luna may also have a ballast weight system above and/or below the front dome (not present on all Luna systems).

Buoyancy can be adjusted when the ROV is in the water, and is covered in



[Section 12.7: Buoyancy and balance](#)

7.8.3 Lights

The lighting arms are adjustable. Slightly unscrew the ballast ring caps to pull the lighting arms out and tighten the caps to hold the lights in position. Lights can also be rotated on the ball mounts at the end of each lighting arm.



8 Powering on the Boxfish Luna

Please follow the below power on sequence to ensure the proper operation of the camera inside the Luna.

8.1 Power on Control Station

IMPORTANT!

DO NOT connect any accessories (if using) to the Control Station USB ports before powering it up. Accessories using the USB ports can be attached after the Control Station has booted.

Press the green **ENABLE** button to power up the Control Station. Wait until the system boots (up to a minute).

8.2 Power on ROV with magnetic key

Take a magnetic key and hold it to green ON pad on the back of the ROV. The Status LEDs inside the rear dome will light up for the power on sequence.

During the sequence, the following lights will appear:

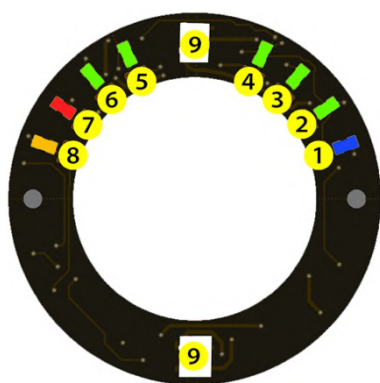

1. Blue (1): ROV is powered on
2. Green (2): Critical power needed to drive ROV is OK
3. Green (3): Power required for front camera video feed is OK
4. Amber (8) blinking: Control system is OK.

Some/all of the green lights 4, 5 and 6 will light up if you have accessories or external sensors installed on your ROV.

If you do not see the amber blinking light or all lights are flashing, see [Section 19: Troubleshooting](#).

8.3 View feeds on telemetry screen

An introduction to the telemetry screen is below. The telemetry screen is



covered in more detail in [Section 13: Piloting your ROV](#).

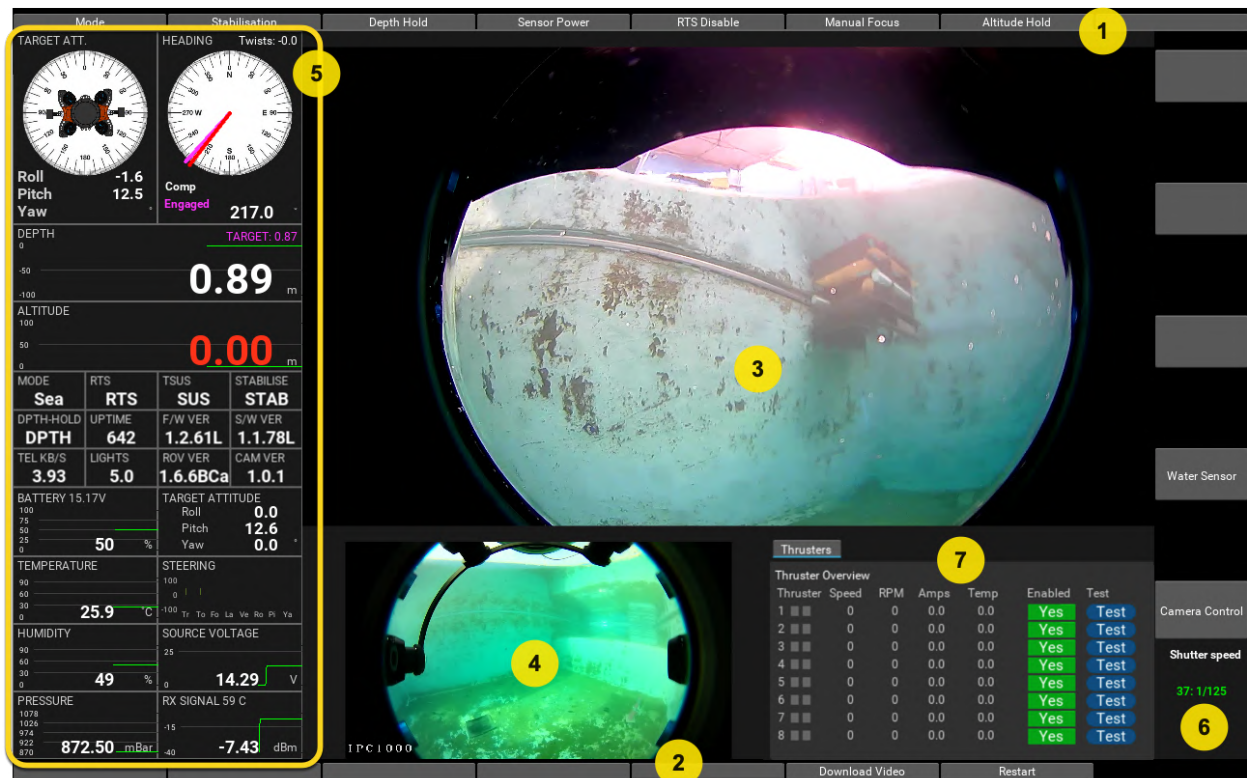

1.	Button/switch labels	For buttons and switches above the screen.
2.	Button labels	For buttons underneath the screen.
3.	Front nav cam	Front wide-angle navigation camera. Provides best situational awareness for piloting the ROV.
4.	Reverse nav cam	Wide-angle view from the rear nav cam.
5.	Telemetry data	Various data received from the ROV. Includes: DEPTH: Depth in m according to ROV depth sensor UPTIME: No. of seconds since the ROV was powered on with the magnetic key. Useful to confirm communication between ROV and Control Station BATTERY: Remaining voltage, % remaining and trend line PRESSURE: Pressure in mBar inside the ROV RX SIGNAL: Indicates signal loss over the tether. This value should be somewhere between -7 and -20dBm.
6.	Camera Control GUI	A small Graphic User Interface to control settings for the front camera. See Boxfish Luna Camera



		Operations Manual for usage instructions and confirmation that the camera has started correctly.
7.	Widget tabs	Tabs: Tabs may include Thrusters, USBL or OSD. Thrusters tab is used to turn off/on individual thrusters (see Troubleshooting section). Usage of USBL and OSD tabs will be detailed in separate manuals or instructions. Tabs can be selected by connecting a mouse to one of the Control Station USB ports.

Note: Sometimes the navigation cameras feeds do not come through on first start-up of the Control Station. If they don't appear, press the Restart button (bottom right button below the telemetry screen).

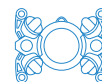

9 Pre-deployment checks

This section outlines the tasks that need to be done before putting your Luna into the water. It is important to practise these procedures and complete them before every dive.

9.1 Camera setup and testing

If you need to access the front camera (for example to access memory card, change settings or affix a different lens) we recommend you do this in a safe and stable setting BEFORE packing up your ROV for the dive.

We also recommend thoroughly practising the camera controls and trying out the various ways of recording and retrieving photos and video footage. See the **Boxfish Luna Camera Operations Manual** for instructions.

9.2 Apply and test vacuum on ROV pressure vessel

To protect the ROV from water ingress, a vacuum is set inside the pressure vessel.

Vacuum is applied using the ROV's vacuum port. The vacuum port consists of:

- A screw-on cap that holds the vacuum release valve in place. Ensure the cap is in place at all times when not pressurising or depressurising the ROV.
- A pressure valve that can be pulled out to release the vacuum in the chamber.

IMPORTANT!

Ensure the PRESSURE reading on the telemetry screen remains constant for ten minutes while at the surface to ensure the ROV is watertight.

To set a vacuum (875mbar), follow these steps:

1. Locate the vacuum pump and hose inside the accessory box and connect the hose and pump together.
2. Take the cap off the vacuum port on the rear of the ROV. Keep the cap in a safe place.

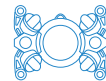

Unscrewing cap from vacuum port

3. Hold the green end of the vacuum hose firmly to the vacuum port. It must be flush against the ROV to make a seal. Slowly squeeze the trigger of the vacuum pump and then release – this action will suck air out of the ROV. You will see the PRESSURE reading on the telemetry screen begin to fall. It will take a minute or two for the pressure to fall to 875 mBar.



Holding the vacuum hose in place while pressurising the ROV

4. When the pressure reaches 875mbar, the status LEDs in the rear dome will flash off and then back on, and the ROV will beep quietly.
5. Screw the cap back onto the vacuum port.
6. Wait 10 minutes to confirm that the PRESSURE reading remains constant. It may rise due to increased temperature inside the ROV when it is powered on, but should not rise much more than 5mbar during these 10 minutes.

IMPORTANT!

Wait for 10 minutes after applying vacuum to ensure it does not rise above 5mBar.

Replace cap on vacuum port before use.

DO NOT set a vacuum of below 850mbar.



9.3 Test LED illumination lights

9.3.1 Practise setting lighting arm configuration

Note: We recommend waiting until the ROV is in the water before setting the position of the lights, as it can be awkward to get the ROV into the water with the lighting arms extended.

7. Slightly unscrew the ballast chamber caps on the ends of the ROV frame tubes so that the lighting arms are free to move.
8. Rotate the arms and light panels as desired. In general, keep the lighting arms out for reduced backscatter, and in closer for close-up work and tight spaces. The lights should also be rotated slightly outwards from the dome to reduce reflection from small particles in the water.
9. When happy with the configuration, tighten the ballast chamber caps to maintain position of the lights.

9.3.2 Check lights are working

Turn the **LIGHTS** switch on the Control Station to the ON position. **Note:** To prevent damage to the LED modules, the lights will operate at a maximum of 5% intensity while the ROV is out of the water.



WARNING!

DO NOT look directly into the Luna's LED illumination lights.

9.4 Inspect and test thrusters



WARNING!

DO NOT touch the thrusters when the ROV is on or serious injury may occur. Keep fingers, long hair and loose clothing or anything that may become entangled well clear of the thrusters when operating.

1. Visually inspect the thrusters to confirm they are free from damage or foreign material.



2. When ready to test thrusters, press and hold the **OK (✓)** button for six seconds. The ROV will emit a sequence of beeps as a warning to keep away from the thrusters.
3. The ROV will rotate each thruster for a few seconds, in sequence from 1-8, as shown in the diagram below.

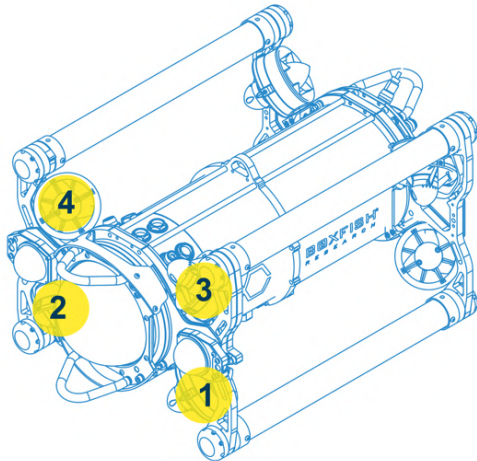

Front thrusters

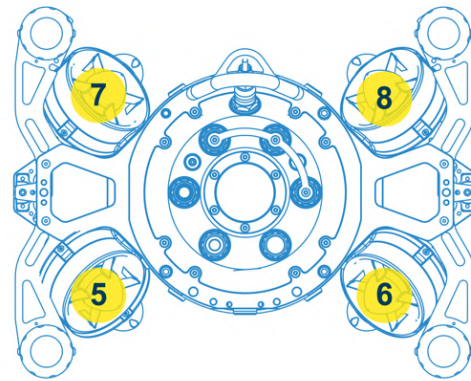

Rear thrusters

4. During the test, verify each thruster is rotating properly.

Note: Thrusters may be slightly noisy during surface testing as they are designed to operate underwater.

9.5 Test scaling lasers (if present)



WARNING!

DO NOT look directly into the ROV scaling lasers. They emit **Class 3R laser light**.

If the optional scaling lasers are fitted to your ROV, turn the **LASERS** switch to the ON position. Turn the switch to OFF after your test.

9.6 Lubricate tether penetrator O-rings

It's good practice to lubricate the O-rings on the tether penetrator (at the end of the tether cable) **before every dive** to maintain the watertightness of this part. The parts requiring lubrication are:

- The two O-rings on the brass tether penetrator



- The O-ring that is contained inside the black knurled collar on the tether penetrator – this O-ring is not visible but still needs regular lubrication.

To lubricate the O-ring inside the collar, unscrew the knurled collar and take off the tether penetrator protective cap. Squeeze a tiny amount of silicone grease onto your fingers and apply it to the bottom of the collar, between the collar and the metal body of the tether penetrator. Then, move the collar back and forward to get the grease inside the collar to lubricate the O-ring inside.

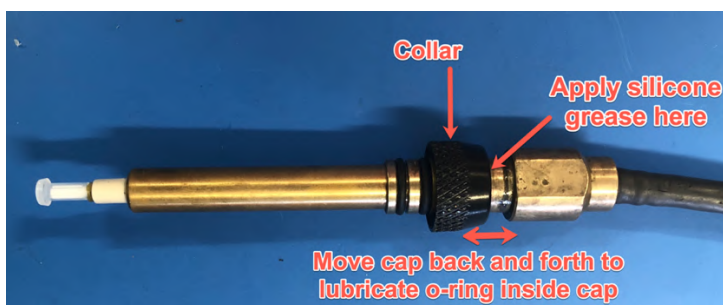

Lubricating the O-ring inside the collar of the tether penetrator

9.7 Test external devices and Luna configurations

It is likely that your Luna has several hardware configurations available, for example:

- External sensors (sonar, USBL, DVL or other)
- Acrylic or glass front domes or flat ports
- Different camera lenses.

If your ROV has any external devices that require power from the ROV, view the applicable manual for how to these out of the water.

Changing the configuration of hardware on your Luna will impact buoyancy and it will need to be re-balanced. See instructions in [Section 12.7: Make ROV balanced and neutrally buoyant](#).

Note: most accessories are designed to be used in water, so do not leave them powered on for long periods at the surface.

9.8 Practise adding ballast washers (and ballast bars, if present)

Familiarise yourself with the Luna's balancing systems and the method for removing and adding ballast washers and ballast bars (if present).



10 Boxfish Luna pack up sequence (from out-of-water testing)

Now we'll practice packing up the ROV so it's easier in the field. For additional post-dive tasks, see [Section 16: After-dive procedures](#).

Note: When the ROV is packed away, batteries should be at storage voltage. Make sure the batteries are not fully charged during storage (unless you will be diving within the next 24 hours), otherwise the batteries can be damaged. See **Boxfish Battery Charging Manual** for instructions.

10.1 Power off Ninja V Recorder

Power off the Ninja and detach all components from the Control Station.

10.2 Power down ROV

Hold the magnetic key over the red OFF pad. The rear LED lights will turn off when the ROV is powered down.

10.3 Power down Control Station

Press and hold the red **STOP** button on the Control Station for **six seconds** to power it off.

10.4 Unplug tether from ROV

Follow the steps below. Practice these several times so you can perform them quickly and confidently and minimise exposure of the fibre optic connections.

1. Find the black plastic tether penetrator protective cap (should be attached to the tether reel with Velcro).



2. Unscrew the nut of tether port plug and separate it from the black plastic tether penetrator cap.
3. Unscrew the nut and pull out the tether penetrator from the ROV.
4. IMMEDIATELY replace the tether port plug into the tether port of the ROV. Do this step first because it is the most difficult connection to clean if any water/dust/humid air gets in.
5. Cover the end of the tether cable with a clear plastic dust cap.



6. Put the black plastic tether penetrator protective cap on the end of the tether penetrator, and screw in the knurled nut so that it can't come off.



7. Carefully wind tether cable back onto tether reel. Apply light tension to the tether cable to wind it on neatly.

10.5 Disconnect fibre patch cable

Note: Pull fibre patch cable straight out (not at an angle) to avoid damaging the connector inside the fibre ports.

Get the 2x coloured port caps and 2x clear plastic dust caps ready.

1. Disconnect the fibre patch cable from the tether reel.
2. Quickly put the clear plastic dust cap on the end of the cable and put the red cap on the port.
3. Disconnect the fibre patch cable from the Control Station.
4. Quickly put the clear plastic dust cap on the end of the cable and put the red cap on the FIBRE port.

10.6 Pack away other components

Pack all cables, accessories, and Ninja neatly in the Accessory Box. Return Control Station to the top of the Accessory Box. Affix dome protector and return the Luna to its case. Detach winder handle from tether reel and pack tether in its case. Store all boxes in a stable, cool, and dry place.



11 Planning your dive

This section outlines some of the things you need to consider when preparing for a mission with your Boxfish Luna. It is essential that you take the time to plan how and where it will be used.

11.1 Charge ROV Battery

Allow enough time to fully charge the ROV battery pack to its full capacity (16.8V) before your dive.

For instructions, see our **Boxfish Battery Charging Manual**. Latest version is available on our website: <https://www.boxfish.nz/downloads/>

11.2 Safety

This manual cannot possibly predict all possible conditions you will encounter while using your ROV. Nor can we specify all the planning and risk mitigation steps you need to take as ROV operators.

Human safety should always take precedence over equipment and dive objectives.

Some things to consider are:

- How to safely achieve your dive plan and objectives
- Team members – who will pilot the ROV and who will manage the tether cable? How will you communicate effectively?
- Weather conditions
- Sea / water conditions
- Underwater hazards
- Communication with others, eg divers, boat skipper
- Contingency / recovery plans for the ROV in the worst case.

11.3 Research your launch vessel/site

Consider the vessel or location for launching your ROV. Plan ahead for the following:

- **Control Station placement:** the Control Station is splashproof but not waterproof, so ideally needs to be indoors or in a covered location. Consider how you will power the Control Station and place it close to its power



source. Bright sunlight can also make the 17" UHD screen difficult to view, so a shady spot is ideal. It is not necessary for the ROV pilot to be able to see the tether reel or ROV (before it enters the water); good communication with team members is more important.

- **Length of fibre patch cable:** choose a suitable length depending on the distance between the Control Station and tether reel. Consider how you will minimise the risk of tripping over this cable.
- **Tether reel placement:** the tether reel operator and Control Station operator need to be in frequent communication.
- **Height of launch spot:** the ROV should not freefall into the water from a height of more than 1 metre – utilise the lifting eye on the top of the ROV if the launch site is higher than this and deploy carefully by rope. If the ROV's buoyancy needs to be adjusted, this should be done before the dive.

11.4 Depth rating of your ROV and external devices

Your ROV may be rated to a different depth than your external device(s) – always check before planning your dive. Do not operate your ROV or any external devices below their depth ratings.

Nauticam glass front domes also have maximum depth ratings.

Ask us if unsure what the limits of your equipment are.

11.5 Hazards

Potential hazards are listed below; what others can you think of? How will you minimise these hazards during your dive?

- **Trip Hazards:** Tether cable, fibre patch cable, tether reel, storage cases, ROV, Control Station, tether, power cable for Control Station.
- **Injury Hazards:** tether reel mechanism, lifting heavy items, sharp protruding objects (like grabber or cutter).
- **Damage to ROV or external devices:** Scratching or causing cracks to domes, dropping and damaging the tether penetrator, stepping on tether cable, bending or damaging the tether cable, leaving fibre optic cable ends or ports without caps, water ingress to ROV or Control Station, exceeding depth limits.
- **Misplacing items:** fibre cable caps and fibre port caps, tether penetrator cap, tether port cap, tools/spares out of the Accessory Box.



11.6 Keeping the ROV cool

The ROV should be kept cool (below 30C) while out of the water. During transport to the dive site, keep the ROV in the shade and away from hot areas such as engine rooms.

Avoid leaving the ROV in the sun for long periods – if this is impossible, cover with a wet towel. Also avoid leaving the ROV powered on while out of the water.



12 Deploying your Boxfish Luna in the water

12.1 Overview

This section explains how to launch your ROV. Before deployment, it is essential that you have connected and powered on the ROV system correctly and completed the pre-deployment checks in previous sections.

IMPORTANT!

For new ROV operators, we recommend carrying out the tasks in this section and [Section 13: Piloting your ROV](#) during several practice sessions in a controlled setting such as a pool where it is easy to put the ROV in/take it out of the water.

12.2 Assembling Boxfish Luna for a dive

Reference [Section 7: Putting together the Boxfish Luna System](#) to assemble your ROV.

12.3 Power on ROV and Control Station

Reference [Section 8: Powering on the Boxfish Luna](#) to complete the following:

1. Power up the Control Station and then the ROV.
2. Check all video feeds are displaying as expected.
3. Check that the ROV has enough battery power to complete your dive.
4. Check telemetry information to verify there is good communication between the ROV and Control Station (UPTIME and Rx SIGNAL).

12.4 Pre-deployment checks

Check your Luna is operating correctly by performing all the following:

1. **Camera checks:** Check that the camera and Ninja are set up with your desired recording settings according to the separate **Boxfish Luna Camera Operations Manual**.
2. **General checks:** Complete the checks in [Section 9: Pre-deployment checks](#).

12.5 (If installed) Turn on Sensor Power switch for external devices



If your ROV has any external devices or sensors installed (eg altimeter, sonar, USBL, grabber or other) turn on the **Sensor Power** switch to the ON position just before you put the ROV in the water.

12.6 Put ROV in the water

When you are happy the ROV is watertight and operating correctly, gently put it into the water. You should be able to easily reach the ROV while performing the next step: checking and adjusting buoyancy.

Note: Once the water sensor (on the rear dome) detects the ROV is in the water, the status LEDs at the rear of the ROV will automatically turn off.

12.7 How to balance your ROV and make it neutrally buoyant

You will need to balance your ROV at the time of deployment if:

- You have added/removed parts such as external sensors or domes that affect its weight or buoyancy
- You wish to dive in salt water.

12.7.1 Add extra ballast if using ROV in salt water (after fresh water)

Add extra ballast washers if your ROV is new (as it will be balanced for fresh water at our factory), or if it was previously balanced for fresh water.

To change from freshwater to salt water, start by adding eight ballast rings to each chamber at the front (32 in total) and six to each chamber at the back (24 in total). This won't achieve perfect balance but is a good starting point.

12.7.2 Test balance with current ballast

To test buoyancy with the ROV's current ballast, hold the ROV under the surface and move it around so that all the air escapes from the frame tubes and around external components. Let go of the ROV and observe if it sinks or floats.

12.7.3 Add or remove weights to achieve balance and neutral buoyancy

Note: The below steps will take time and patience. Allow around 30 minutes to balance your ROV until you get more experience.

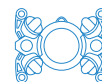

To determine where to begin adding or removing weights:

3. When all trapped air has escaped from the ROV frame, observe which parts of the ROV are the heaviest and lightest. Light parts will pop out of the water, and the ROV will turn itself upside down while floating upwards if a bottom frame tube is under-weighted.
4. Try to determine if the ROV needs weights added or subtracted. If the ROV is light, it will require a net addition of weights; if the ROV is heavy, it will require a net subtraction of weights
5. Once the ROV seems like it has the right amount of weight, you can start moving the weights around between the chambers to achieve neutral buoyancy in its upright orientation first, so that it is sitting just below the surface of the water
6. Rotate the ROV onto its side and adjust buoyancy in this orientation
7. Repeat for upside down and other side orientations
8. The ROV should be suspended in an upright position just below the surface of the water when properly balanced.

Note: You can remove the caps from the ballast holders to make it easier to add/remove weights. The springs inside should keep the weights in position. However, note that without the caps in place, the lights will move out of position and will affect the balance, so be sure to move them back into place before final balancing.

12.8 Check depth sensor

Check that the depth reading on the telemetry screen looks correct. If not, while the ROV is at the surface, push the **Depth Hold** switch to the FN position to zero the depth reading.

12.9 Begin launch sequence



WARNING!

Keep fingers, long hair and loose clothing or anything that may become entangled well clear of the thrusters before you begin the launch sequence.



Launch sequence:

1. Do a final check of the Pressure and Battery readings on the Control Station.
2. Turn all switches on the Control Panel to the OFF position (except the Sensor Power switch if using).
3. Press the green **Enable** button on the Control Station (once, short press).
This will activate the thrusters. When thrusters are operating, the TSUS label on the telemetry screen will change to from SUS (suspended) to ARMD (armed).
4. Turn the **Stabilisation Hold** and **Depth Hold** switches ON once the ROV is stable and level.

At the end of the launch sequence, the thrusters should be keeping the ROV suspended in a fixed position just below the surface of the water.



13 Piloting your ROV

13.1 Useful telemetry screen info for piloting

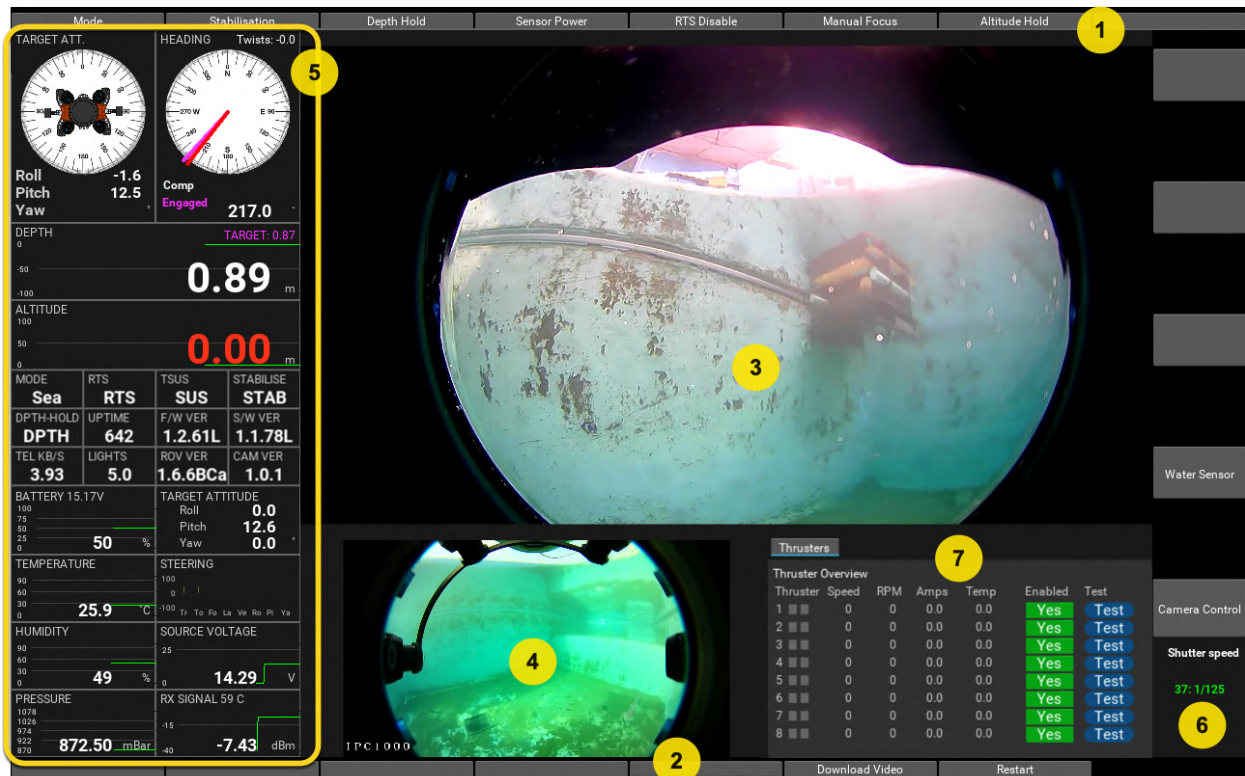

Note: Some items on your telemetry screen may differ from this picture

- TARGET ATTITUDE:** shows target input from the sticks for each of: Roll, Pitch and Yaw.

HEADING widget: shows the direction according to the ROV's internal gyro or compass.

UPTIME: Should be counting upwards to indicate there is still a connection between the Control Station and ROV.

MODE: Piloting mode. Sea Mode, ROV Mode, Sea-Q Mode or ROV-Q Mode.

RTS: RTS for RTS Disable on or nothing displayed for RTS Disable off.

STABILISE: STAB for ON or nothing displayed for OFF.

DPTH HOLD: DPTH for ON or nothing displayed for OFF.

STN-HOLD: ON if Station Hold is on (requires DVL).

LIGHTS: Current percentage power for the ROV lights.

PRESSURE: Monitor this via the trend line to ensure no sudden loss of pressure.

Rx SIGNAL: Will be a negative value indicating signal loss over the fibre connections. If outside normal range of -6dBm to -10dBm, can indicate



	tether is twisted, knotted, excessively bent or that fibre connections need cleaning. We recommend making a note of this value before your ROV goes into the water and monitoring it during a dive. When this value approaches -20dBm it is likely that some of the video feeds or telemetry data will be interrupted.
7.	7. Tabs include Thrusters, USBL (will display data from USBL accessory) or OSD (On Screen Display). USBL and OSD are optional extra features and will not be available unless ordered. More tabs may be included depending on your order.

Note: The full list of labels on the telemetry screen are explained in [Appendix II: Telemetry Screen – More Information](#).

13.2 Moving the ROV

Boxfish ROV's eight thrusters allow it to freely move in six degrees of freedom: it can move along its vertical, longitudinal and lateral axes, as well as rotate on them, as shown below.

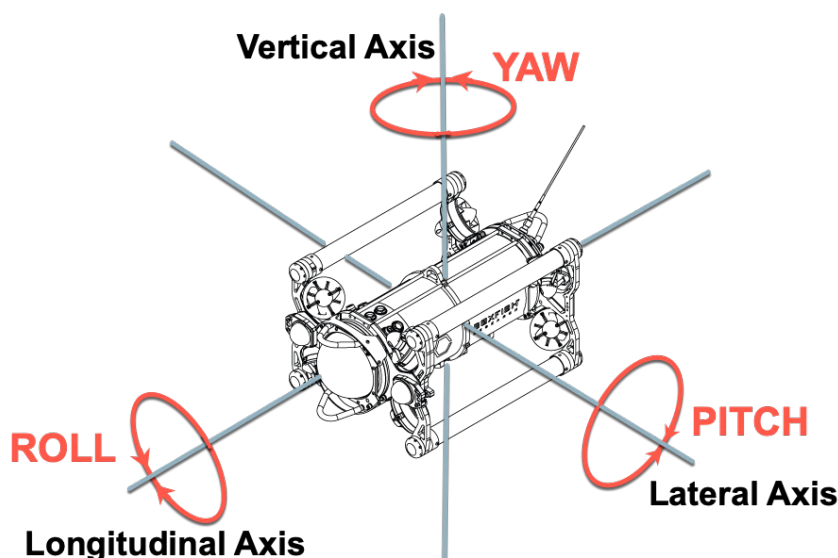

5. Vertical descent / ascent: the ROV will move up and down along its vertical axis
6. Horizontal left / right: the ROV will move left and right (“crab”) along its lateral axis
7. Horizontal forward / back: the ROV will move forward and back along its longitudinal axis
8. Pitch forward / back: the ROV will tilt up (so that the nose is up) or down (so that the nose is down) on its lateral axis



9. Yaw left / right: the ROV will turn left and right on its vertical axis
10. Roll left / right: the ROV will tilt left and right (“bank”) on its longitudinal axis.

13.3 Piloting modes

There are four modes available. Sea Mode is the default on startup. Press the **Mode** button to cycle through the other three modes: Sea-Q Mode, ROV Mode, and ROV-Q Mode.

13.4 Sea Modes

Sea Modes are the easiest for beginners to master.

In **Sea Mode** (which is the default mode) and **Sea-Q Mode**:

- The ROV’s horizontal and vertical axes are aligned with the earth’s, regardless of the pitch or roll of the ROV.
- Joystick inputs will move the ROV relative to the earth. For example, using the left joystick to increase depth will move the ROV closer to the centre of the earth, and moving it forward or sideways will move it horizontally along the earth’s surface.
- When piloting the ROV you will tend to set the pitch first (if required), and then pilot the ROV with mainly the left and right joysticks.
- **Example:** If the ROV is pitched down and you are moving the ROV forward with the right joystick, the ROV will move forward along the earth’s surface while looking down. This is useful if you wish to use the ROV to film a transect (single line) along the bottom.

13.5 ROV Modes

ROV Mode (or ROV-Q Mode) allows the ROV to be operated like a dolphin, and can be useful when working relative to sloped surfaces such as a ship’s hull or sloping sea floor. ROV Modes are more difficult to master than Sea modes, so we recommend getting comfortable with Sea Modes first.

In **ROV Mode** or **ROV-Q Mode**:

- You must **turn off Depth Hold**.
- Joystick inputs are aligned with the axes of the ROV (not the Earth). So, the ROV will move in the direction it is pointing.



- (In ROV Mode) When piloting the ROV you will tend to use the right joystick in conjunction with the pitch/roll joystick to move the ROV.
- To move down a slope on the bottom with varying gradient, you would pitch the ROV down and move it forward to move the ROV down the slope, and adjust the pitch for the different gradients.
- **Example:** If the ROV is pitched down and you move the ROV forward with the right joystick, the ROV will make a diagonal dive towards the bottom.

13.6 Controls for Sea Mode and ROV Mode (non-Q modes)

13.6.1 Left joystick

In non-Q modes, the **LEFT** joystick is used to control the ROV depth and lateral movement.

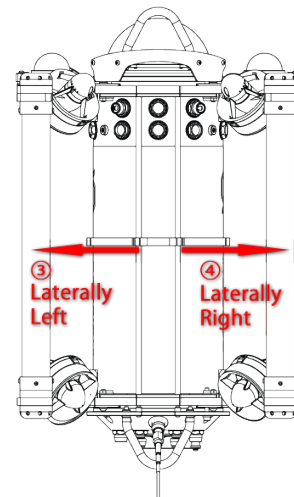
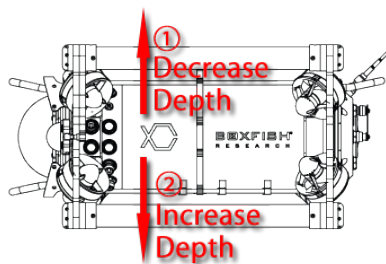

11. Move the joystick away from you to move the ROV up towards the surface
12. Move the joystick toward you to increase depth / move the ROV vertically down
13. Move the joystick to the left to move (“crab”) the ROV left (to port) along its longitudinal axis
14. Move the joystick to the right to move (“crab”) the ROV right (to starboard) along its longitudinal axis.

13.6.2 Right joystick

In non-Q modes, the **RIGHT** joystick is used to control the ROV yaw and forward and backwards movements.

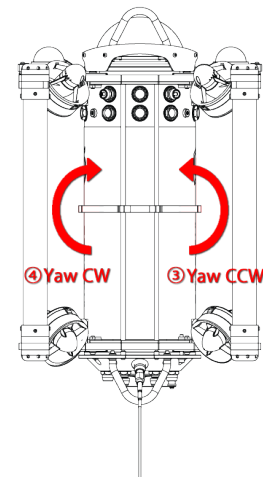
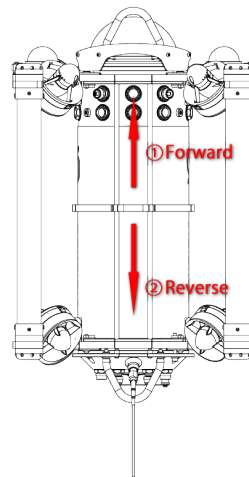
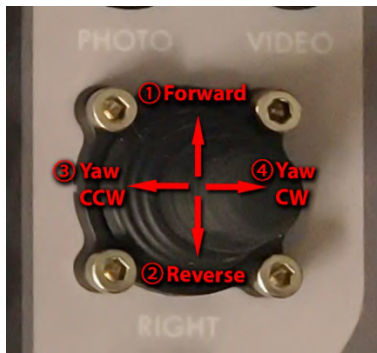

15. Move the joystick away from you to move the ROV forward.
16. Move the joystick towards you to move the ROV in reverse.
17. Move the joystick LEFT to rotate the ROV on its vertical axis. The ROV will rotate to the left / anti-clockwise / counter-clockwise.
18. Move the joystick RIGHT to rotate the ROV to the right / clockwise.

13.6.3 AUX joystick

In both Q and non-Q modes, the **AUX** joystick controls the ROV pitch and roll.

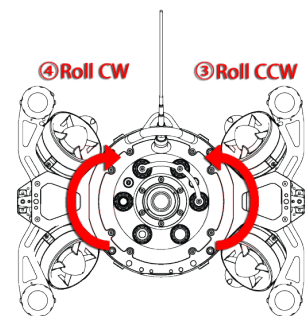
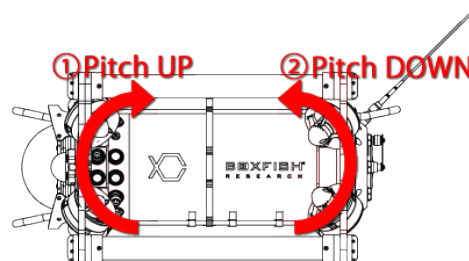
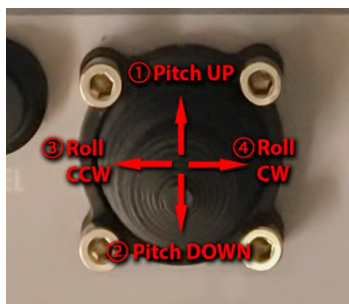

19. Move the joystick away from you to make the ROV pitch up. The ROV will rotate on its lateral axis. The front of the ROV will move up while the back of the ROV moves down.
20. Move the joystick towards you to cause the ROV to pitch down. The ROV will rotate on its lateral axis. The front of the ROV will tilt down while the back of the ROV moves up.
21. Move the joystick LEFT to roll the ROV to the left (anti-clockwise / counter-clockwise / CCW) on its longitudinal axis.
22. Move the joystick RIGHT to roll the ROV to the right (clockwise / CW) on its longitudinal axis.



13.7 Controls for Quad Modes (Sea-Q Mode and ROV-Q Mode)

If you are used to flying drones, you may wish to make use of these modes – the Q stands for “Quadcopter”. The only difference in these modes is that the lateral and yaw movements in the left and right joysticks are swapped. So, moving the left joystick to the left or right will change the yaw, and moving the right joystick left or right will move the ROV in a lateral “crab” movement.

13.8 Speed

The speed of the ROV is controlled by the thrust control thumb wheel. It is used to increase or decrease the maximum power applied to the thrusters for a given movement of the control joysticks. Fully to the left is minimum and fully to the right is maximum power. We recommend keeping it at the 1/3rd setting. **Note:** giving more power to the thrusters will drain the ROV battery pack faster.



13.9 Depth Hold

The ROV will be most stable when Depth Hold is on. It is possible to move the ROV up and down without Depth Hold affecting stability: the ROV will hold the new depth. Note:

- If operating in a swell, turn off Depth Hold until you are below the influence of the swell to prevent the ROV moving up and down with the swell.
- If you require the ROV to be near the surface, keep it at or below 0.5m from the surface and activate Depth Hold to avoid it breaking the surface.

13.10 Heading Hold

IMPORTANT!

Heading Hold uses the ROV's compass for direction stabilisation, and therefore requires the ROV's internal compass to be calibrated and operational. The ROV will be difficult to control if Heading Hold is on when the compass is not properly calibrated.



To drive the ROV on a fixed heading: hold the Stabilisation Hold switch up to the FN position for six seconds. The **H-Hold** label will appear in the HEADING widget.

Note: It is best to turn off Heading Hold when filming as it can cause jerky movements when correcting heading, which can interfere with stability.

13.11 Altitude Hold

If your ROV has an altimeter or DVL, its altitude will be displayed on the telemetry screen. To keep a fixed altitude from the bottom, turn on Altitude Hold. Detailed information on usage and limits are available in the manual for each accessory.

Note: if both Depth Hold and Altitude Hold are on, altitude hold will take priority.

13.12 Using the LEVEL button

Short press: At any point in your dive, you can press the **LEVEL** button (with a short press) to return the ROV attitude to a neutral (zero) roll and pitch state. Pressing the button will cancel any current roll and pitch settings.

Long press (10 seconds): Use this if you notice the ROV moving on its own (and you are sure it is well balanced). The following procedure will zero the joystick controls:

1. Take your hands completely off the joysticks for 10 seconds.
2. Press the LEVEL button for 10 seconds
3. Wait for 20 seconds following this press before touching the controls again.

13.13 Adjusting the ROV LED illumination lights

Turn the **LIGHTS** switch to ON. Control the intensity with the left dial. In most situations you can keep the lights around 20%. Note that lights are a significant factor in using up the battery. If you wish the rear navigation LEDs to be off, use the dial to dim the lights until they turn off.

13.14 RTS (Return to Surface)

Return to Surface will be enabled by default when you power on your ROV (ie



the “RTS Disable” switch will be in the OFF position).

When RTS is on, the ROV will automatically return to the surface after 10 minutes if it loses contact with the Control Station. To verify RTS is on, check you can see the letters “RTS” in the **RTS** field on the telemetry screen.

13.15 When to disable RTS (Return to Surface)

If you wish to explore enclosed spaces such as cave, pipe, or shipwreck where the vertical path to the surface is obstructed, turn RTS off (turn the RTS Disable switch to the ON position).

13.16 Battery monitoring during your dive

As you become more familiar with your Luna, you will learn how it functions and how much time to expect out of a full battery charge.

Use the **Battery** value on the telemetry screen to see how much battery is remaining. The trend line will give you clues as to what functions are draining the battery faster than others.

Variables that you as ROV Pilot and tether operator can control are:

- Speed of thrusters using the thrust control thumb wheel
- How far you push the joysticks in each direction
- Intensity of LED illumination lights
- Tether cable tension – there is too much tension on the tether cable causing the ROV to work against it.

Some external variables affecting battery life are:

- Current
- Swell
- Depth / visibility (and therefore use of lights).

13.17 Battery limits

Aim to be **back at the surface with 14.7V remaining** in the batteries.

The ROV will automatically shut down its thrusters between 14.3 and 14.1V, and will power off completely at 13.7V to preserve its battery pack. Avoid



discharging the battery completely: it is dangerous and will reduce the life of the battery pack.

13.18 Piloting tips and tricks

- If operating in a swell, turn off Depth Hold until you are below the influence of the swell to prevent the ROV moving up and down with the swell.
- If you require the ROV to be near the surface, keep it at or below 0.5m from the surface and activate Depth Hold to avoid it breaking the surface.

13.19 Notes

- Navigation cameras will turn to black and white at depth or in dark environments. This is by design to produce a better picture.
- You can see the status of individual thrusters using the **Thrusters** tab on the telemetry application. Unfortunately, there is no way to tell if a thruster is not working due to entanglement or other interference, but the ROV may exhibit strange behaviour or become difficult to control. See [Section 19: Troubleshooting](#) if you are unable to control the ROV.



14 Managing tether cable during a dive

Good tether management during a dive is essential for safety and performance of your ROV and to ensure the fibre cable inside is protected from excessive stress (including bending, knotting or twisting) which could cause loss of communications or breakage.

14.1 Safety

- Your dive plan (for suggestions, see [Section 11: Planning your dive](#)) should note people or entanglement hazards in the water.
- The tether and patch cable are a trip hazard on deck / on shore.
- If the tether should break, do not handle the exposed end(s).



WARNING!

If the fibre optic tether cable should break, DO NOT handle the exposed ends. It is best to tape over the ends immediately. The fibre inside is extremely sharp and can easily penetrate the skin, break off and be very difficult to remove.

14.2 Avoiding snags, knotting of tether

- ROV pilot and tether operator should be in constant communication to unspool tether to allow free movement of the ROV, or bring tether back in tether to avoid excess tether in the water.
- Tether operator should not allow excess tether to be unspooled into the water, otherwise tether could become snagged on an object or knotted.
- The pilot should check the rear camera at regular intervals to make sure the tether cable does not appear too loose.

14.3 Avoid pulling on tether while ROV is filming

- The tether operator should not pull the tether with any tension, otherwise the ROV may have to work against the tether. **Note:** All pull force on the tether will be transferred along its length, even if the tether itself has formed a curve in the water due to current or movement of the ROV and/or boat. Pulling on the tether will not cause it to straighten out. The pull force will simply be transferred directly to the ROV and limit its movement.



14.4 Tips

- At the start of the dive, you might find it easier to unspool some cable from the tether reel onto the deck to pay out as the ROV descends.
- When the ROV is returning to the surface, leave the excess cable on deck until you have time to wind it onto the reel properly. This allows the tether cable to be rinsed easily to get rid of salt/debris before winding it onto the drum.
- Take care not to make a mess of the tether cable when winding it onto the drum. Keep a bit of tension on the tether when winding it on.

IMPORTANT! DO NOT wind the ROV from depth with the tether reel.



15 ROV surfacing and retrieval

15.1 How to bring ROV back to surface

1. Manoeuvre the ROV towards the surface: As with descending, it's easy to do this along a fixed reference such as an anchor line or wharf pile. If there is no fixed reference, it's often easiest to return the ROV to the launch point by turning the ROV around and following the tether.
2. Recover the tether as the ROV ascends. If it is ascending too fast to wind onto the drum, recover it onto deck and wind it on later.
3. Monitor the ascent via the **DEPTH** reading on the telemetry screen. When the ROV reaches approximately 5m depth, turn on the LED illumination lights to make the ROV easier to see.
4. When the ROV breaks the surface, disable the thrusters by pressing the red **STOP** button (single short press) on the Control Station.
5. Lift ROV out of the water (two people) and place on deck.

15.2 Removing the ROV from the water

Pay attention to all safety items:

- Do not lift the ROV out of the water using the tether
- Ensure thrusters have been disarmed and are not spinning before retrieving ROV from water
- Retract lighting arms before lifting the ROV out of the water
- Take care not to damage external devices while lifting the ROV out of the water
- Use two people to lift the ROV out of the water.

15.3 Power down ROV

1. Turn off the ROV by holding the magnetic key over the red OFF pad.

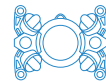

16 After-dive procedures

This section outlines how to take care of your ROV after a dive.

16.1 Disconnect ROV components and cables

IMPORTANT!

To avoid damage to your ROV, carefully follow the pack down procedures from [Section 10: Boxfish ROV pack up sequence](#). Do not allow fibre connections to be exposed for too long: replace caps immediately after disconnection.

16.2 Rinse ROV, tether, and any accessories

As soon as possible after your dive, rinse the ROV and tether to remove salt, dirt and debris. Fresh water is ok in the short term. If the ROV will be stored for longer periods, clean it and all accessories with warm and soapy water (dish soap is ideal) to prevent corrosion.

1. Make sure ROV is watertight, and all ports are covered / plugged.
2. Hose down the ROV thoroughly with fresh water to clean off any salt, dirt and debris picked up during operation. If no hose is available, you can fill the ROV Pelican Case with water and immerse the ROV for at least an hour.
3. Check thrusters for debris.
4. Direct a stream of water to flush out any debris and salt from the pressure sensor at the rear of the ROV.
5. Rinse tether cable and tether reel.
6. Wash dome with warm soapy water to get rid of any grit.
7. If you have any accessories, such as a grabber, wash thoroughly to get salt out from the crevices.

16.3 Leave ROV components to dry

Dry all components. Leave lids on all cases open for at least 72 hours to ensure no moisture remains on the inside of the cases when they are closed.

Check dome for grit. Only wipe clean with an optical lens cloth if no grit is present, otherwise the dome may get scratched.



16.4 Attend to ROV battery

As soon as possible, get your battery pack back into storage voltage. See our **Boxfish Battery Charging Manual** (latest version available on our website: <https://www.boxfish.nz/downloads/>).



17 Storing your ROV

IMPORTANT!

Follow the instructions in this section carefully to ensure the ongoing operation of your ROV.

When you are not actively using your ROV, it must be stored correctly to look after its battery and internal electronics.

17.1 Prepare for storage

The ROV and its components should be washed with warm, soapy water to prevent corrosion, then left to dry completely.

ROV components should be stored in their original cases with all protective wrapping and padding.

The Control Station should be stored inside the Accessory Box.

17.2 Storage conditions

The storage area should be a cool, dry area with a stable temperature.

17.3 Adjust battery to storage voltage

Before storing, prepare the ROV battery pack to storage voltage of 15.6V, see the **Boxfish Battery Charging Manual** for instructions.

17.4 Monthly maintenance during storage

Don't forget about your ROV while it's in storage! It still needs attention:

- The front camera contains an internal battery which should not be allowed to go flat, otherwise the camera will lose its time/date and other settings.
- The ROV batteries cannot be allowed to drain, otherwise they will be unusable.
- To keep your ROV in optimum condition, every month, use the monthly maintenance procedure described in the **Boxfish Battery Charging Manual** before storing for another month.



This is also a good chance to give the ROV a once-over check for corrosion or anything unusual, and let us know.



18 Updating your Luna system

We will regularly release updates for your Luna.

18.1 Items required

- A USB memory stick
- Computer
- Boxfish ROV, connected to Control Station via tether or dummy tether.

18.2 Relevant buttons and labels

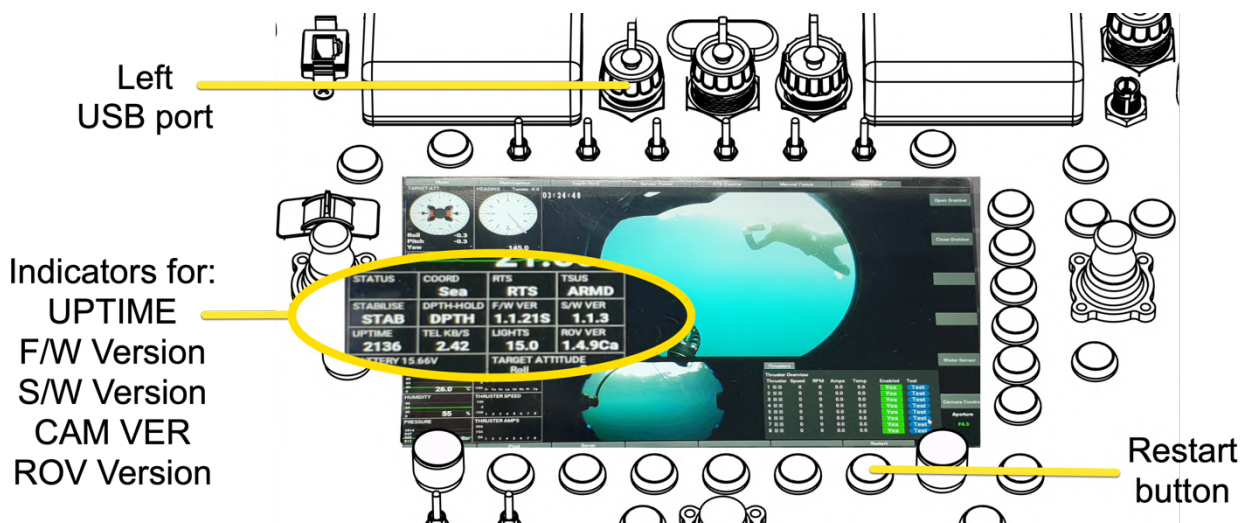

18.3 How to update Luna Control Station and camera

1. **Prepare memory stick:** Create a folder called FIRMWARE (all capitals) on your memory stick. It should be at root level, ie not contained within any other folders. If you have already created this file for prior updates, delete the old files so that the folder is empty.
2. **Transfer update files onto USB stick:** We may send you one or all of the below update files. Move the files into the FIRMWARE folder on your memory stick. Note: don't unarchive (double-click on) the .tgz file.

Update filename	Device	Telemetry screen label
ControlStation*.hex	Control Station firmware	F/W VER
ControlStation*.tgz	Control Station software	S/W VER
CamSoftware*.tgz	Camera control device	CAM VER

* will be replaced with the version number of the update.



3. **Transfer files onto USB stick:** Move the files into the FIRMWARE folder on your memory stick.
4. **Power on ROV and Control Station.**
5. **Insert memory stick:** Insert into the left USB port of the Control Station. Don't touch any controls until the update is complete.
6. **Wait about five minutes:** You will hear the ROV and Control Station beep during this time.
7. **Press restart button:** Check the labels on the Control Station to see if the F/W VER, CAM VER and S/W VER match the version numbers in the file names.

Note: If any of the updates did not succeed, remove the files that DID update from the FIRMWARE folder. Then, insert the USB stick again and try again to complete the remaining updates.

18.4 How to update ROV

1. **Prepare memory stick:** Create a folder called FIRMWARE (all capitals) on your memory stick. It should be at root level, ie not contained within any other folders. If you have already created this file for prior updates, delete the old files so that the folder is empty.
2. **Transfer update files onto USB stick:** The file will be named ROV*.hex (where * will be replaced by the version of the update). Move the file into the FIRMWARE folder on your memory stick.
3. **Transfer files onto USB stick:** Move the files into the FIRMWARE folder on your memory stick.
4. **Power on ROV and Control Station.**
5. **Insert memory stick:** Insert into the left USB port of the Control Station. Don't touch any controls until the update is complete.
6. The **UPTIME** counter will stop counting after about 20 seconds.
7. Wait (up to 15 minutes) until **UPTIME** starts counting again. When it starts counting again, the **ROV VER** label on the telemetry screen will show the new firmware version.

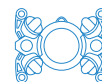

19 Troubleshooting

This section covers troubleshooting issues relating to testing and operations of the Luna. See the **Boxfish Battery Charging Manual** for battery-related troubleshooting and **Boxfish Luna Camera Operations Manual** for troubleshooting related to camera operations. Both are available at <https://www.boxfish.nz/downloads/>.

19.1 Potential issues and solutions

Issue	Solution
All status LEDs are blinking after ROV is powered up	If the status LEDs are not lit up as expected after the ROV is powered on (with the amber blinking light), check that all three charging port plugs are properly in place and screwed in for all three charging ports.
Thruster test does not work	Check all ports on the rear of the ROV are covered. The thruster test won't start if any of the port covers are not in place. The battery port covers must be pushed in fully before tightening the knurled cap. Also check that the tray is properly secured with the four bolts are tightened as much as possible, (without being over-tight) so that the connectors inside can meet.
ROV thrusters won't enable	If you can't enable the ROV thrusters as part of the launch sequence, check the following: <ul style="list-style-type: none"> ■ Follow the launch sequence exactly as described in Section 12.11: Launch sequence. ■ Check that the status LEDs inside the rear dome are off while the ROV is in the water. If the lights are on, contact us as there may be a problem with the water sensor. ■ Check that the link between the ROV and Control Station is working by looking at the UPTIME counter – it should be counting upwards.
Video feeds from ROV are interrupted or intermittent	Possible solutions: <ul style="list-style-type: none"> ■ Check the Rx value on the telemetry screen to ensure fibre cable is not twisted or the fibre connections are dirty.



	<ul style="list-style-type: none"> ■ If you suspect the connections are dirty, use the pen cleaner and/or cleaning sticks to clean the fibre optic ports and cable connections (see Section 20.3: Cleaning the fibre optic connections). ■ If you clean the fibre connections and the Rx value (negative value) is approaching -20dBm, try connecting another fibre patch cable from your Accessory Box. ■ Restart the telemetry application using the Restart button. Note: Disconnect devices from Control Station USB ports (such as USBL and GPS) before using the Restart button.
<p>Feed from front camera stops completely</p>	<p>This can happen if the ROV is left out in the sun, or if the ROV has been operating for a long time.</p> <ul style="list-style-type: none"> ■ Check the telemetry screen and if the internal temperature inside the ROV is 30C or over, turn off the ROV and put it in the shade or cover with a wet towel until it cools down. ■ Hold down the Video button for six seconds to restart the camera system. <p>It's also possible the 17" screen input has been accidentally changed:</p> <ul style="list-style-type: none"> ■ Press the left-most button under the screen slowly and repeatedly until the camera feed returns.
<p>Video feed from front camera does not appear on startup</p>	<p>If a settings screen from the camera appears asking you to select a language, it means the camera's internal battery is flat. See Section 19.5: Clear camera settings screen from main camera screen.</p>
<p>Navigation camera freezes</p>	<p>Use the Restart button on the telemetry screen to restart the telemetry application. The feed from the navigation camera will be refreshed. While the application restarts you can still use the navigation controls as normal.</p>
<p>Navigation camera(s) goes black and white or stops</p>	<p>The navigation cameras are designed to go to black and white at depth or when light is low, as this gives a sharper picture. When there is no light at all, the rear camera will shut off.</p>



<p>ROV is behaving strangely and not responding to joystick controls</p>	<p>If the RO exhibits strange behaviour such as moving on its own or not being able to be controlled with the Control Station joysticks, you can try the following:</p> <ul style="list-style-type: none"> ■ Check that the Stabilisation Hold switch is ON. It is very difficult to pilot the ROV without Stabilisation Hold. ■ If you have an altimeter, check that Altitude Hold is not on if the ROV is more than 20m from the bottom. ■ If you are new to using the ROV, ensure the piloting mode is set to one of the Sea Modes. Sea Modes are the easiest to use. ■ If you are more experienced and wish to try ROV mode, the Depth Hold switch must be OFF. ■ If Heading Hold is on, switch it off until you can verify that the compass is calibrated. The ROV will be uncontrollable if Heading Hold is on while the compass is not calibrated. ■ If you suspect the ROV's mechanical control joysticks have become uncalibrated, you can try the long press procedure in Section 13.12: Using the LEVEL button. ■ If none of the above works, bring the ROV to the surface and ensure all the thrusters are working (do a thruster test). ■ If all thrusters are working, the ROV's compass may not be working so please recalibrate its compass by following the instructions below. ■ If none of the above solves the problem, please get the logs from the Control Station (see Section 19.3: How to retrieve log files from Control Station) and send to us for evaluation.
<p>All thrusters stop during a dive</p>	<p>This can happen if the ROV breaks the surface and the water sensor in the rear dome detects that the ROV is not in water.</p> <ul style="list-style-type: none"> ■ Press the green ENABLE button once to reactivate the thrusters. ■ If you need to film close to the surface and are experiencing trouble with the thrusters frequently



	<p>stopping, you can disable the Water Sensor by pressing and holding the Water Sensor button for six seconds. IMPORTANT NOTE: The water sensor is a protective feature which prevents the thrusters from being enabled and protects the LED modules of the lights while the ROV is out of the water. While the water sensor is disabled, thrusters should not be operated while out of the water, and lights should be limited to 5% intensity otherwise the LED modules will be damaged. After you have finished the dive, press and hold again for six seconds to re-enable the water sensor.</p>
<p>Thruster gets damaged or something becomes caught in a thruster during a dive</p>	<p>You can try to turn off the suspected fouled thruster so that you can more easily return to the surface. See instructions in Section 19.4: Thruster troubleshooting. If the propeller or thruster needs replacing, replace according to the instructions in Section 21: Authorised repairs.</p>
<p>(At surface) ROV lights come on if ROV is powered on but not connected to Control Station</p>	<p>This behaviour will occur during monthly maintenance charging. If the ROV is not connected to the Control Station, it will mimic the Return to Surface behaviour and its lights will come on after 10 minutes to indicate that there is no connection to the Control Station.</p>

19.2 How to recalibrate ROV compass

You may need to recalibrate the compass in your ROV on arrival after we ship it to you. It's also likely you'll need to recalibrate the compass if you are using your ROV near one of the Earth's magnetic poles.

Note: It will be easier to perform the in-water steps when the ROV is well balanced and neutrally buoyant.

19.2.1 Prerequisites

Before you start, connect the ROV components together and power up the ROV and Control Station. You will need two people, one with the Control Station and one with the ROV.



1. Put the ROV into the water until it is just below the surface and hold onto it, as you would when balancing the ROV. Note that Depth Hold and Stab Hold switches should be OFF and the ROV should not be armed (ie thrusters should not be enabled).
2. Press and hold the **MODE** button along with the bottom-most button on the right-hand side of the telemetry screen (shown below). Hold both of these buttons simultaneously for **six** seconds to initiate compass calibration.

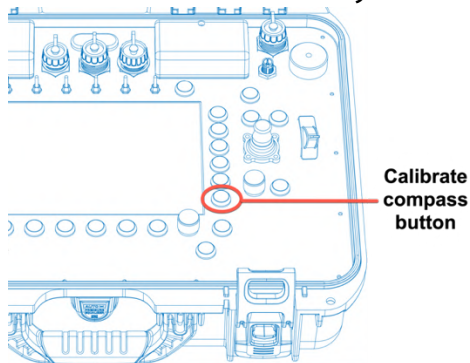

When calibration is initiated the UPTIME counter will stop counting.

3. Immediately after UPTIME stops counting, the person holding the ROV should manually rotate the ROV **two full rotations in 60 seconds**. The ROV should be rotated on its vertical axis (in yaw). It is helpful to use a phone timer app to help rotate the ROV 180 degrees every 15 seconds.

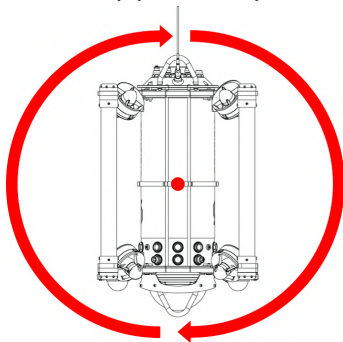

*Vertical axis/approximate centre of gravity indicated by point in the middle.
Rotate ROV around this axis. Note: It does not matter if rotation is clockwise or anti-clockwise.*

4. Immediately following the rotations, the gyro must be calibrated for the next 60 seconds (or until UPTIME starts counting again). The aim of the person holding the ROV is to move it so that it rotates it in all directions around its centre of gravity. So, move the ROV around so that it achieves all of the following positions: pitched up, pitched down, rolled left, rolled right, yawed left and yawed right. The exact pattern and order of these movements is not critical.



5. When the gyro has completed calibration, UPTIME will start counting again. This sometimes takes less than 60 seconds. The person at the Control Station should monitor UPTIME and let the person moving the ROV know when it starts counting again.

19.3 How to retrieve log files from Control Station

We might ask you get log files from the Control Station and send them to us to help us diagnose any issues. To do this:

1. On a computer, create a folder on your USB stick called LOGS (all capitals). Eject the stick.
2. Power up your Control Station (you don't need to connect the tether reel and ROV). Insert the USB stick into one of the USB ports (doesn't matter whether left or right).
3. Wait for 90 seconds. Log files will automatically be transferred onto the USB stick. You can remove the stick from the control station after 90 seconds is up.
4. Attach the USB stick to your computer again and use a compression tool (such as WinZip) to zip the LOGS folder (to compress the files) Then send the zipped file to us by email.

19.4 Thruster troubleshooting

Thrusters can be turned off individually using the telemetry application, and it is possible to pilot the ROV with one or more deactivated thrusters.

If you think that the cause of any issues with control of the ROV is due to a thruster becoming entangled or not working properly, you can turn off those thrusters.

Note that the ROV can be easily controlled with one thruster disabled but will go at half the maximum speed. It is still possible to pilot the ROV effectively with two thrusters disabled, but control will be noticeably reduced. With three or more disabled thrusters it is difficult to control the ROV.

To deactivate a thruster, you will need a mouse. Connect the mouse to one of the USB ports on the Control Station and click on the green label in the **Enabled** column next to a thruster. When deactivated the label will turn red.



Thrusters						
Thruster Overview						
Thruster	Speed	RPM	Amps	Temp	Enabled	Test
1	0	0	0.0	0.0	Yes	Test
2	0	0	0.0	0.0	Yes	Test
3	0	0	0.0	0.0	Yes	Test
4	0	0	0.0	0.0	Yes	Test
5	0	0	0.0	0.0	Yes	Test
6	0	0	0.0	0.0	Yes	Test
7	0	0	0.0	0.0	Yes	Test
8	0	0	0.0	0.0	Yes	Test

If a thruster is obviously not working, replace it or its propeller according to the instructions in [Section 21: Authorised repairs](#).

19.5 Clear camera settings screen from main Control Station screen

The below language setting screen will appear if the camera's [internal battery](#) has gone flat.



To bring the camera feed back:

1. Power off the Luna and take the tray. For full instructions, see the Boxfish Luna Camera Operations Manual.
2. Open the Luna and use the physical selection button on the camera to go through the setup (you may need to move the camera forward to do this).
3. When the camera feed appears again, power off the Luna and reinsert the tray.



20 Regular maintenance procedures

IMPORTANT!

To keep your ROV in good condition for operations, follow the procedures in this section at least as often as our recommendations in this manual.

20.1 Monthly maintenance charging

To maintain optimum condition of your battery pack and internal battery in your RX100 camera, we have a procedure to carry out once per month. See **Boxfish Battery Charging Manual** for procedure.

20.2 Dome care and maintenance

IMPORTANT!

Do not use solvents to clean ROV domes as this will cause irreparable damage and cracks that may not be visible.

- **Front dome:** Keep clean and take extreme care to avoid scratches. To clean, use warm soapy water (dish soap is ideal) to remove grit. When clean and dry, use a microfibre optical cleaning cloth like the one supplied in your Accessory Box.
- **Rear dome:** Take care not to bump or put pressure on this dome as it could cause cracks. For cleaning, use the same method as for the front dome. Inspect regularly for cracks.

20.3 Tether care

Don't bend, twist or pull the tether cable excessively. The fibre inside is well protected by its Kevlar coating however it can be broken if the bend radius is too small, the cable is excessively twisted or pulled too tight.

20.4 As required: cleaning the fibre optic connections

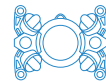

Use these procedures if you are experiencing signal loss over the tether, or interrupted video or feeds from the ROV.



WARNING!

DO NOT look into any of the fibre ports or connected fibre cables while the ROV is powered on. The lasers used to transmit signals over the fibre optic cables is invisible but can cause damage to the retina of the eye.

20.4.1 Clean ends of fibre optic cables

This process is for cleaning the ends of the fibre optic cables at the following points:

- The end of tether cable at the tether penetrator point
- Both ends of the fibre optic patch cable.

To do this, you will use the fibre optic cleaning pen with only the very top of the plastic cap removed, as shown below.



Follow the below steps for each cable end point, taking care to minimise exposure of the cable ends.

1. Remove the top plastic cap from the end of the pen
2. Remove the protective cap from the end of the fibre optic cable
3. Insert the uncapped end of the cable into the end of the pen, as shown below.



4. Push the pen towards the cable until you hear and feel a click
5. That's it! Replace the cap on the cable and the cap on the pen.



20.4.2 Clean fibre optic ports on Control Station and tether reel

Use the fibre optic pen cleaner to clean the following fibre ports:

- Fibre port (labelled FIBRE) on the Control Station
- Fibre port on the tether reel.

1. To clean the fibre ports, remove the entire plastic cap from the end of the pen, as shown below.

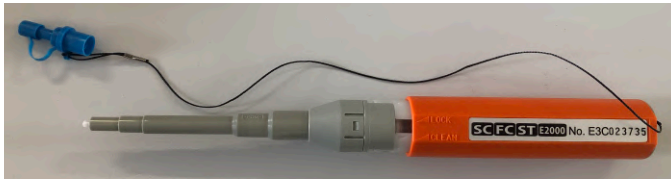

2. Rotate pen so it is in the 'CLEAN' position.



3. Remove the cap from the fibre port on the Control Station.
4. Insert the pen into the input, as shown below. Push the top of the pen down until you hear/feel a click. This click is sufficient for cleaning the fibre optic connection.

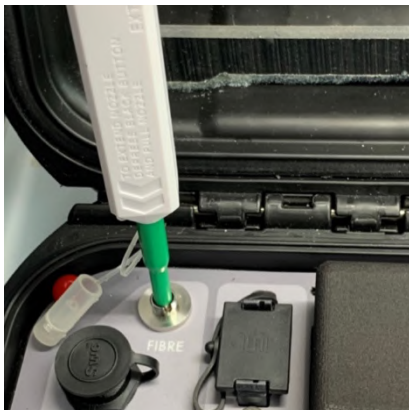

5. Replace the port cap.

20.4.3 Clean tether port on ROV

Use the cleaning sticks for this task.

1. Remove the tether port plug (or tether penetrator, if ROV is connected).
2. Insert one cleaning stick into the tether port. Ensure the swab reaches all the way down into the tether port to the connector inside the ROV.



3. Rotate the swap ten times in a clockwise direction on the connector inside the ROV.
4. Replace the plug (or cable) back into the ROV.
5. Throw away the cleaning swab – they are for **single use only**.

20.5 O-rings maintenance



As with all pressure vessels, good O-ring maintenance is critical to ensure no water ingress into your ROV.

- Keep O-rings clean and clear of dust and dirt
- Lubricate O-rings frequently, especially on parts of the ROV where they are often used, such as tether penetrator and battery charge ports
- Only use O-rings supplied by Boxfish. There are spares in your Accessory Box
- Replace O-rings that form seals of ROV parts that are removed or opened, such as the tether penetrator and battery charge ports, **every year**.

20.5.1 How to lubricate O-rings

Smear a tiny amount of silicone grease on your finger and run the O-ring through your (clean) fingers to lubricate it before insertion. Don't use too much silicone grease as it will attract dust.

20.5.2 List of O-ring spares in Accessory Box

Type / Part #	Spares	Location on ROV	Example picture(s)
14 x 1.5 MOR.014X15N70 / [19112607]	5	O-rings on exterior of: <ul style="list-style-type: none"> ■ Tether port ■ Charge and balancing ports ■ Vacuum port ■ Ports on ROV chassis 	
8.73 x 1.78 OR.011BN70 / [19072310]	4	O-rings on machined brass/plastic penetrators: <ul style="list-style-type: none"> ■ Rear lid port caps ■ Tether penetrator ■ Tether port plug ■ Other port plugs 	

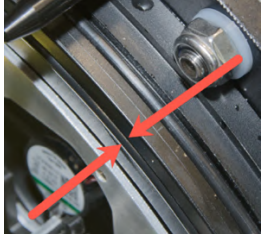
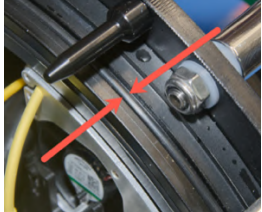

<p>8 x 2 MOR.008X2N70 / [20020837]</p>	<p>4</p>	<p>O-rings on our potted penetrators:</p> <ul style="list-style-type: none"> ■ Thruster penetrators ■ Light penetrators ■ Accessory penetrators 	
<p>177.48 x 2.62 OR.167N70 / [20060440] (new)*</p>	<p>2</p>	<ul style="list-style-type: none"> ■ Rear lid (tray) face seal** 	
<p>190.18 x 2.62 OR.169N70 / [19072305]</p>	<p>2</p>	<ul style="list-style-type: none"> ■ Rear lid (tray) axial seal** 	

* Earlier ROV versions have been supplied part number [19072304] (183.83 x 2.62 OR.167N70) but both O-rings will work for the rear lid face seal.

** These seals are only accessible by opening the battery tray. This procedure is covered in the **Boxfish Battery Charging Manual**.



21 Authorised repairs

We have designed the repair procedures in this section to be simple to carry out in the field. If more complicated repairs are required, your ROV may need to be returned to us (unless agreed with us that these repairs can be done in the field).

21.1 How to release vacuum from inside the ROV

This procedure is a prerequisite for a few other tasks, including:

- Any procedures involving removing the internal tray or battery pack
- Removing or replacing any cables that go into ports in the ROV pressure vessel (such as thrusters, lights or accessories).

1. Unscrew and take off the cap of the vacuum port on the rear of the ROV. Keep the cap in a safe place while you are working.



2. Pull the pressure valve outwards to release the vacuum.



3. Replace cap back onto vacuum port.

21.2 How to replace a thruster



WARNING!

Make sure ROV is powered off before working on or touching thrusters.

21.2.1 About thrusters

We supply one thruster assembly in your Accessories Box. It is an aft thruster (with longer cable). If you need to replace a thruster at the front of the ROV, use a cable tie to secure the extra length of cable.

21.2.2 Prerequisites

- Release vacuum from the ROV, otherwise you will not be able to remove the thruster penetrators.
- Get your Allen Key set from the accessories case.

21.2.3 Removing a thruster

1. Ensure ROV is powered off and vacuum removed
2. Locate the cable and plug for the thruster to be removed. Thruster ports are at the rear of the ROV and are labelled T-1 to T-8.
3. Using your fingers, unscrew the penetrator cap (anti-clockwise) for the thruster cable, and gently pull out the plug. It is secured with two O-rings so you will need enough strength to pull past these.

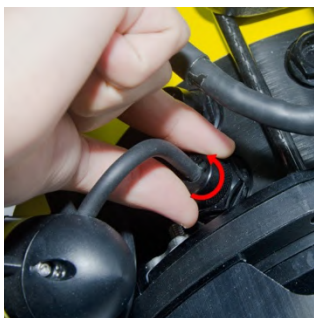

Unscrewing the cap

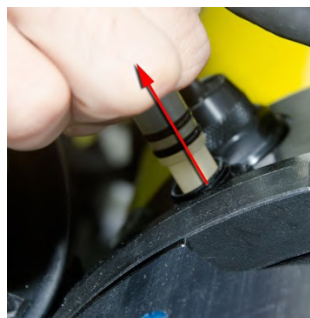

Pulling out the plug

4. Unscrew the 2x screws attaching the thruster to its mounting point on the ROV. Keep the mounting plate and screws in a safe place.

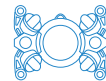

Remove the two screws attaching thruster to its mount on the ROV

5. Carefully remove the entire thruster assembly, including cable and plug.



Thruster (fore, with shorter cable) when removed from the ROV

21.3 How to replace a propeller

You'll need to replace a propeller if it gets damaged, or if you're swapping out a thruster where the replacement propeller does not have the same orientation as the one you've removed.

Spare propellers and fastening screws are included in your Accessories Box.

Tools required: 2mm Allen Key and No. 2 Phillips Screwdriver.

21.3.1 Propeller orientation: CW or CCW

IMPORTANT!

When replacing propellers, you must use a propeller with the same orientation. The propellers have CW (clockwise) or CCW (counterclockwise) written on them for easy identification



Propellers are oriented according to the illustrations below.

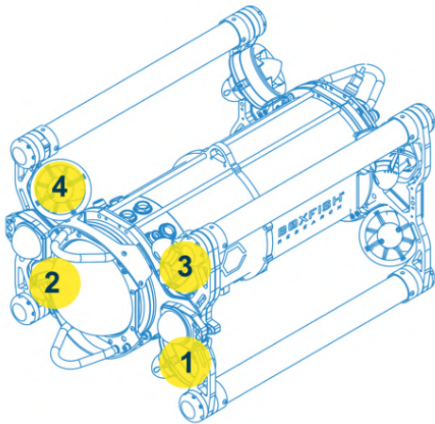

Front propellers

- | | |
|--------|--------|
| 1. CW | 3. CCW |
| 2. CCW | 4. CW |

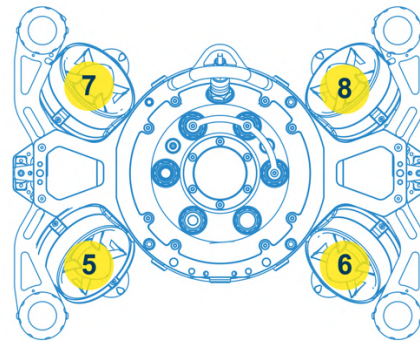

Rear propellers

- | | |
|--------|--------|
| 5. CW | 7. CCW |
| 6. CCW | 8. CW |

Procedure:

1. Ensure ROV is powered off and vacuum removed.
2. Remove thruster and its cable from the ROV (see previous section).
3. Remove the mounting plate on the outside of the cowl/shroud of the thruster. First, unscrew the 4 x hex head screws from the mounting plate. Then, remove the mounting plate. Note: the orientation of the mounting plate on the cowling is determined by aligning the pin on the mounting plate with the pin hole on the cowling.

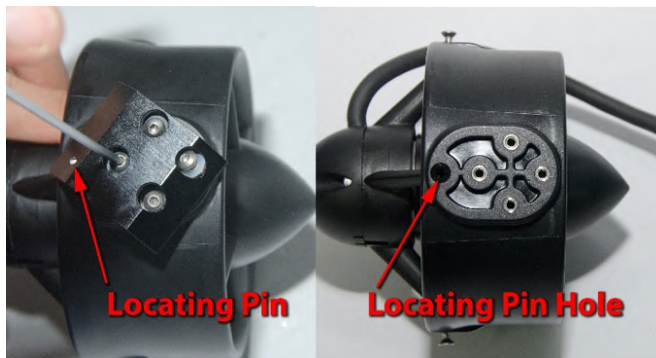

4. Unscrew the three Phillips screws from the cowl/shroud.





5. Slide thruster motor out of the cowling. **Note:** Pay attention to the location of the thruster cable on the cowling so that you can re-insert the motor in the same position after replacing the propeller.
6. Remove the 2 x hex head screws securing the propeller to the motor and slide propeller off.

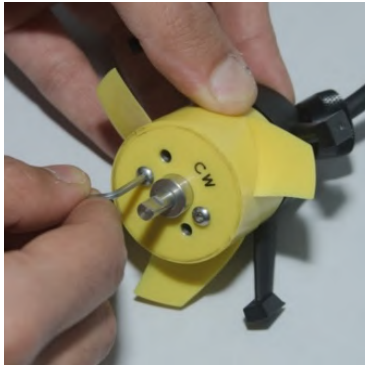

Unscrewing hex head screws Sliding propeller off motor

7. Fit new propeller by gently sliding new propeller onto motor hub. Take care to align the holes in the propeller with the threaded holes on the motor hub. Secure the propeller to the motor using 2 x hex head screws. Do not over tighten or you may damage the propeller.
8. Refit thruster into cowling: Slide thruster motor into the cowl. Ensure the cable is located in the same position as it was when it was removed (if unsure test fit the thruster assembly to check the thruster cable will be facing the correct direction once thruster is refitted). Secure the motor to the cowling using the 3 x Philips head screws. (Note that the screw hole on thruster mount does not have a screw fitted and is used for mounting plate locating pin.)
9. Refit thruster mounting plate: align thruster mounting plate pin with the cowling mounting screw and secure with 4 x hex head screws.

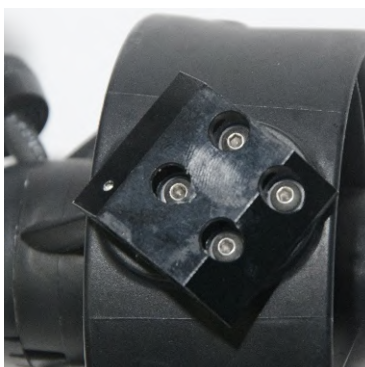

Thruster mounting plate attached to cowling

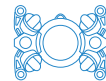

21.4 How to put a thruster back on the ROV



WARNING!

Make sure ROV is powered off before working on or touching thrusters.

IMPORTANT!

Ensure that the thruster's propeller is the correct orientation for its position on the ROV.

1. Ensure ROV is powered off and vacuum removed
2. Ensure that the thruster's propeller is the correct orientation for its position on the ROV (CW or CCW).
3. Line up the threaded holes on the mounting plate with the holes on the thruster mounting point on the ROV. Ensure thruster cable is not trapped and is in the correct orientation to allow it to be plugged into the thruster port.
4. Slide the 2 x hex head screws through the ROV mounting point into the thruster mount. Tighten with an Allen key.



Thruster mounting point

5. Carefully plug in thruster cable. Align the three holes on the thruster cable plug with the three pins in the thruster port. Note: the plug is not keyed, i.e. the orientation of the three pins does not affect operation. Do not force the plug into place or you could push the connector into the ROV, requiring the ROV to come back to the factory.



Three pins in the thruster port

6. Screw on the cap of the cable until it is firmly finger tight.



Before cap is screwed back on



Cap should be finger tight

7. Power on ROV and perform a thruster test to confirm thruster is working correctly.
8. Check ROV can hold a vacuum.

21.5 ROV LED lights replacement procedure

Note: spare lights are not supplied with your ROV unless ordered.

When replacing an LED illumination light on the ROV, the whole light assembly (example shown below) must be replaced.



Boxfish LED illumination light assembly

21.6 Tools required

- Circlip pliers
- Allen key set supplied with your ROV.



21.6.1 Removing existing light assembly

Overview of steps required:

1. Power off ROV and remove vacuum
2. Remove tray from ROV
3. Unplug the applicable light penetrator plug from its port
4. Remove the clip from the penetrator nut
5. Slide the penetrator nut off the cable
6. Unthread the cable
7. Unscrew the fastener attaching light assembly to lighting arm
8. Remove light assembly.

21.6.2 Power off ROV, remove vacuum and remove tray

IMPORTANT!

The battery tray must be removed from the ROV before proceeding with light replacement to prevent the risk of shorting the ROV's light circuit.

Ensure ROV is powered off and vacuum removed. Then, remove the ROV tray. The tray contains the ROV battery, therefore instructions are contained in the **Boxfish Battery Charging Manual** (available at <https://www.boxfish.nz/downloads/>)

21.6.3 Unplug light penetrator plug

1. Locate the light to be replaced and follow its cable to its port on the ROV body. Light ports are labelled with L and the number of the light, eg L1. **Note:** You may wish to take pictures of how the cable is threaded through the lighting arms so that you can rethread the cable later.
2. Unscrew black knurled penetrator nut to expose the light penetrator.
3. Unplug the light penetrator from the port. This is held in place with two O-rings so a firm grip is required.



Light penetrator removed from port

4. When the penetrator is unplugged, take your circlip pliers and remove the clip from inside the black knurled penetrator nut.



Penetrator nut with clip inside



Removing clip with circlip pliers

5. Slide the penetrator nut over the end of the cable.
6. Unthread the light cable.
7. Remove the fastener (M4 x 16 aluminium cap screw) from the back of the light.
8. Keep entire light assembly, capscrew and penetrator nut together in one place.

21.6.4 Install new light assembly

IMPORTANT!

Take care when inserting the new light connector into the light port. Do not use force. The connector on the inside of the chassis is easily damaged.

1. Fasten light to its mounting point on lighting arm.
2. Thread cable through lighting arm, referencing pictures from before or by looking at cable of opposite light.
3. If not already attached, attach penetrator nut and clip.

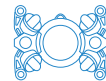

4. Plug lighting penetrator into lighting port. To do this, you will need to line up the metal pin protruding from the light penetrator with the hole in the port. It can help to shine a light into the port before installing the plug so you can see where the hole is.



Pin on light penetrator that must line up with hole in light port



Red circle indicates position of pin hole in light port

Note: Please take care when inserting light penetrator into the port so as not to damage the pin or connectors.



Another view of light port with pin hole visible

5. Screw penetrator nut to hold cable in place.
6. Adjust cable so that lights can be fully extended and fully in.

21.6.5 Power on ROV to test vacuum and light

Test ROV can hold a vacuum and that the new light assembly works as expected.



21.7 Changing time zone on Control Station

If you wish, you can change the timezone of the Control Station to your local timezone (if it is not set to your local time already). Timestamps appear on Log files from the Control Station.

To change the timezone to your local time you will need to connect a mouse to one of the USB ports.

1. Press the Restart button on the Control Station. This will restart the telemetry application.
2. Click the icon with 9 dots. You will need to do this quickly, before the start-up process is too far along. If you see the Python logo appear on the left side of the screen it is too late, and you should press the Restart button again.

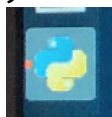

3. Click the Settings icon (middle right).

4. In the Settings window, click **Details** in the left-hand menu.

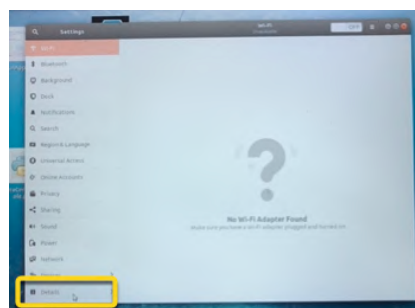
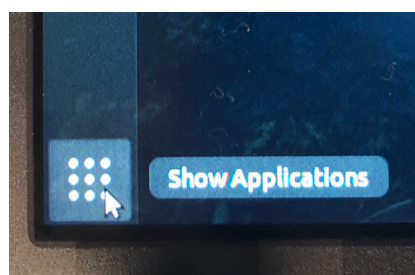

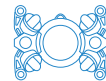

5. Click Date & Time in the left-hand menu.

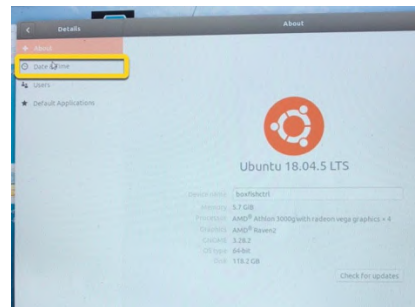

6. Click to select the Time Zone.

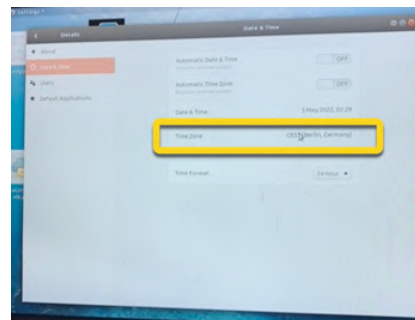

7. Click on the map to select your Time Zone and city.

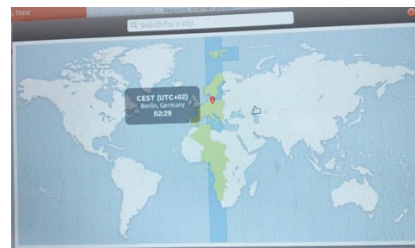

8. Close the window with the red x icon.

9. Click on the Python logo to return to the telemetry screen.

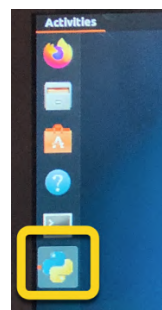



22 Shipping or travelling with the ROV

It is important to prepare the ROV carefully for shipping or travel to avoid damage, delays or fines.

IMPORTANT!

Please pay careful attention to instructions in this section. Failure to properly prepare your ROV for travel could void your warranty.

22.1 Returning your ROV to us for service or repair

In accordance with our Terms of Sale (see <https://www.boxfish.nz/support/terms-conditions/>), you are responsible for arranging shipping and insurance if you need to return the ROV to us for repair or service. We will arrange return of your ROV to you after repair/service.

Please contact us for guidance on paperwork and values for customs purposes.

22.2 General preparation

Before the ROV travels you will need to:

- Release any vacuum from the ROV
- Ensure the ROV is clean and dry
- Use all original padding and protective parts supplied (eg front dome cover)
- Use the original Pelican cases for storage.

22.3 Preparing ROV battery pack

Please see the **Boxfish Battery Charging Manual** for the procedure for getting the battery to the correct voltage for shipping or travelling (15.0V).

Requirements for shipping lithium batteries depend on:

- Your shipping provider. Please contact them ahead of time to clarify their rules.
- Airlines. Refer to the guidelines supplied by your airline. These are based on the latest IATA requirements:



(<https://www.iata.org/en/programs/cargo/dgr/lithium-batteries/>) however each airline makes their own rules for transport of lithium batteries.

You will need to below sticker to the ROV's shipping case and include your contact details:



Include all documentation about batteries that are required by your shipping provider. We can supply Materials Safety Data Sheets and other paperwork if required. Please contact us at support@boxfish.nz if you need assistance.

22.4 Packing the ROV components

To avoid damage:

- Your ROV system and all components should be packed in their original Pelican Cases, with all supplied protective inserts and protective padding.
- We also recommend putting the Pelican cases inside the original padded cardboard boxes used when we shipped the ROV to you.
- DO NOT ship or travel with the Control Station outside of the Accessory Box as it is not designed to be shipped separately. Doing so could result in damage and repairs will not be covered by your warranty.

IMPORTANT!

The Control Station should always be stored inside the Accessory Box when not in use. The 17" screen can be damaged by placing heavy weight on the lid, and the internal components can be damaged or come loose if it is shipped outside the Accessory Box.

22.5 Meeting weight limits for air travel



The heaviest item in your ROV kit will be the ROV case. It may be possible for you to check the ROV into the hold if it weighs close to the weight limit for your airline – in many cases this is 30kg but please check with your airline in advance.

Note that some Luna ROVs may never get to less than 30kg (heavier ROVs tend to have reinforcements for higher depth rating, more sensors, bigger front domes etc). Some ideas for removing weight from the ROV case are below.

22.5.1 Removing battery pack and/or batteries from battery pack

Your best option for removing weight from the ROV is to take out the battery pack, which weighs around 4kg.

Please see our **Boxfish Battery Charging Manual** for instructions.



LiPo BATTERY WARNING!

If not handled according to our instructions, LiPo batteries could leak corrosive substances, emit toxic gases, catch fire or explode.

22.5.2 Removing handle from Pelican case

This video on the Pelican website explains how to remove the handle and castors assembly from the back of the ROV Pelican case.

<https://www.pelican.com/us/en/discover/videos/replacing-the-wheels-on-storm-im2500-and-im2620-cases/>



23 Appendix I: Control Station – more information

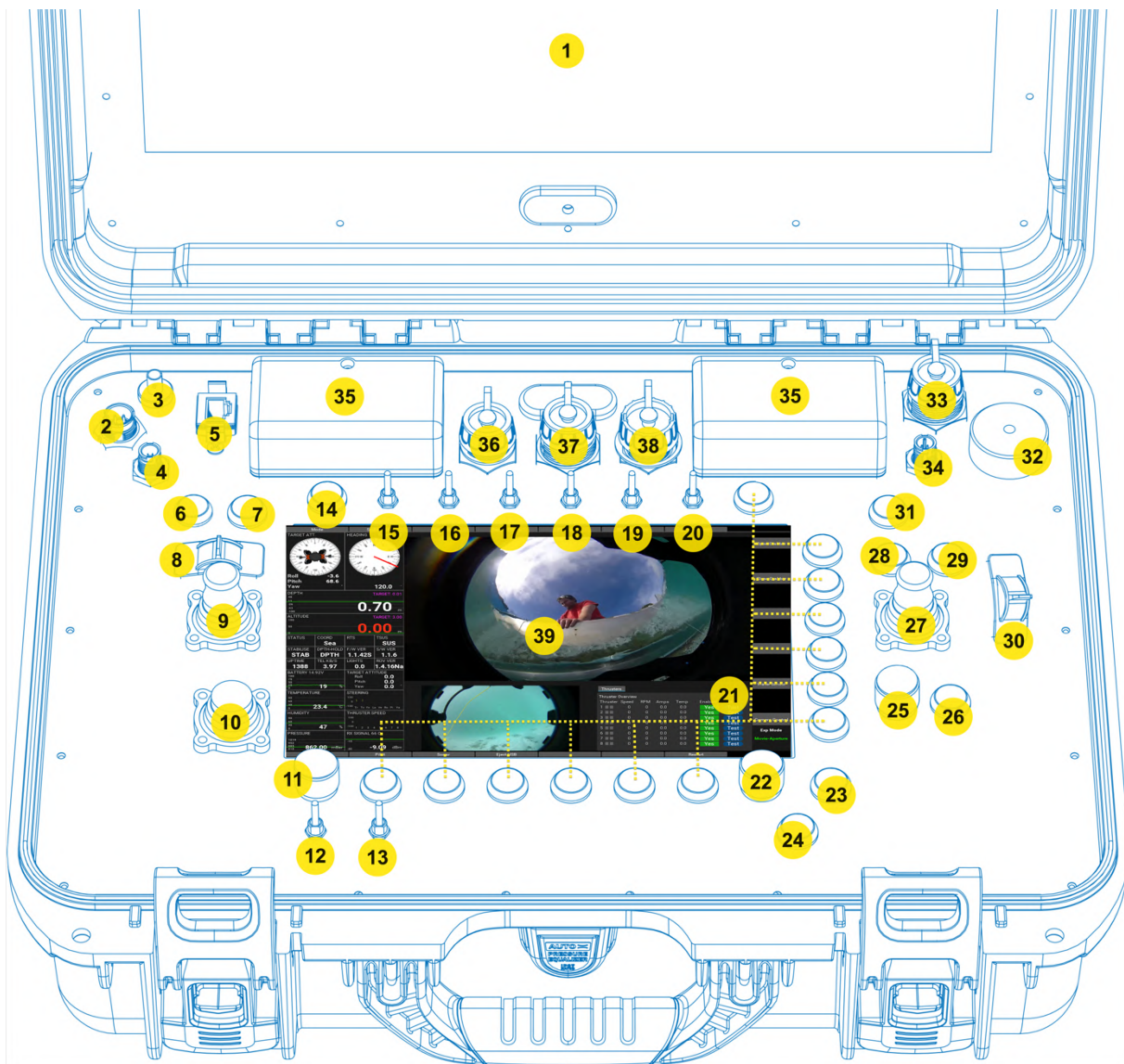

1.	17" 4K Monitor: Displays video feed from front camera
2.	POWER: Power in port. Provides power to the Control Station, via: <ul style="list-style-type: none"> ■ Boxfish AC Adapter (15 Volts 13.4 Amps), OR ■ Directly from a DC supply capable of supplying 10 Amps with the Boxfish DC Power Cable, OR ■ Boxfish DTap power cable.
3.	FIBRE communication port: used to send/receive telemetry, control signals and video between the Control Station and the ROV.
4.	EXT port. Supplies 12V and can be used to power the local USBL beacon (if USBL accessory is supplied). Usage is described in the USBL manual.

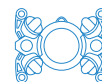

5.	ETHERNET: RJ45 network port. Can be used to connect a laptop/computer to the Control Station to view data from certain accessories on the ROV (eg sonar, USBL, fluorometer). Usage will be detailed in the accessory manual.
6.	LEVEL button. Short press used to restore the ROV to zero roll and pitch. Long press used to zero the controls (sticks should be neutral). See Section 13.12: Using the Level button .
7.	ENABLE button. Used to control the following functions: <ol style="list-style-type: none"> 1. Power on the Control Station - When the Control Station is off, a single short press will power on the Control Station. 2. Enable the ROV thrusters in the water - during the launch sequence, pressing the Enable button again will enable the ROV thrusters. The Telemetry Screen TSUS display will change from "SUS" (Suspend) to "ARMD" (Armed).
8.	THRUST control thumb wheel: used to increase or decrease the maximum power applied to the thrusters for a given movement of the control joysticks. Fully to the left is minimum and fully to the right is maximum power. It is recommended to keep the wheel at the 1/3 rd setting unless more power is required.
9.	LEFT joystick. In Sea Modes, used to control the ROV Depth and Lateral movements. In ROV Modes, used to control the ROV Depth and Yaw movements.
10.	AUX joystick. Used to control the ROV Roll and Pitch movement.
11.	Left dial. Adjusts the intensity of the ROV LED Illumination lights. Turn to the left to decrease intensity and turn to the right to increase intensity of the lights. Note that to protect the LED modules, lights will operate at a maximum of 5% when the ROV is out of the water.
12.	LIGHTS switch. Turns the LED illumination lights OFF and ON.
13.	LASERS switch: If the lasers accessory is present fitted this switch will turn the scaling lasers on and off. ON - Turn on the scaling lasers. DO NOT look directly into the ROV scaling lasers. The scaling lasers emit Class 3R laser light. OFF - Turn off the scaling lasers.
14.	MODE Button: used to switch between the four ROV operating modes for directional controls. Pressing the button will cycle through the ROV operating modes. Current setting is displayed under COORD on the telemetry screen.





	<ol style="list-style-type: none"> 1. Sea Mode – This is the default operating mode. Movement is relative to the body of water the ROV is in. In Sea Mode thrusting forward will cause the ROV to move in a forward direction and keep the current depth and pitch even if the ROV is pitched up or down. 2. ROV Mode – Movement is in whichever direction the ROV is pointing. Turn off Depth Hold if using ROV Mode – In ROV Mode thrusting forward will cause the ROV to move directly forward relative to the centre line of the ROV. If the ROV is pitched up, then the ROV will move forward and up at the same time. 3. Sea-Q Mode: The same as Sea Mode except the yaw and lateral controls (horizontal movements on the left/right joysticks) are reversed. 4. ROV-Q Mode: The same as ROV Mode except the yaw and lateral controls (horizontal movements on the left/right joysticks) are reversed. <p>Also, must hold the Mode button and Cancel (X) button simultaneously to initiate compass calibration. See Section 19: Troubleshooting for details.</p>
15.	<p>Stabilisation Switch: ENABLE and DISABLE the ROV stabilisation function</p> <ol style="list-style-type: none"> 1. ON – With the switch on the built-in stabilisation system will automatically assist with stabilising the movement of the ROV making it easy to move the ROV in the direction required and stay on course. When switched on, STAB will appear on the telemetry screen. 2. OFF – With the switch off the ROV movement is based on control inputs but the ROV will not attempt to compensate for unexpected drift or direction changes. When switched off, nothing will appear on telemetry screen. 3. FN – Pressing the switch up to the FN position twice in quick succession will change between Gyro and Compass for heading stabilisation. <p>FN – Pressing the switch up to the FN position for six seconds will enable Heading Hold (note Compass must be used for heading stabilisation and compass must be calibrated otherwise ROV will be difficult to control when Heading Hold is on).</p>



16.	<p>Depth Hold switch: Enable or Disable the Depth Hold function. Also, the FN position can SET the zero (0) depth setting of the ROV.</p> <ol style="list-style-type: none"> 1. ON - The ROV will hold the current depth set relative to the surface. Depth can still be changed using the Left Joystick. 2. OFF - The ROV will not attempt to keep its current depth, eg If the ROV is pitched down and you move forward the depth will increase. 3. FN - Push to FN position and hold for six seconds to zero the current depth reading. Will only work if indicated depth is less than 5 metres. 4. FN - If DVL is present, pressing the switch up to the FN position twice in quick succession will activate Station Hold (position hold).
17.	<p>Sensor Power switch: Turns power to external sensors/accessories on the ROV (eg USBL, altimeter, sonar, grabber) ON or OFF. We recommended you do not operate these sensors for extended periods while out of the water.</p> <ol style="list-style-type: none"> 1. ON - With the switch on power will be sent to any external sensor and it will be operational. 2. OFF - With the switch off no power will be sent to any external sensor and it will not operate. 3. FN - Currently no function.
18.	<p>RTS Disable switch (Return To Surface Disable): Enable or Disable the Return to Surface (RTS) Disable function.</p> <ol style="list-style-type: none"> 1. ON - With the switch ON the RTS function is DISABLED and the ROV will not initiate an automatic return to surface if communication to the Control Station is lost. This mode is useful when in enclosed spaces like a cave, pipe or shipwreck where the vertical path to the surface is obstructed. 2. OFF - With the switch OFF the RTS function is ENABLED. If the ROV loses communication to the Control Station for more than 10 minutes the ROV will attempt to return to the surface automatically. 3. FN - Currently no function
19.	<p>Manual Focus switch: set the focus mode of the main camera.</p> <ol style="list-style-type: none"> 1. ON - Set the main camera focus mode to MANUAL FOCUS. The camera will keep the current focus setting and not change focal distance. To refocus the camera either push the switch to the FN position or use the Focus button.

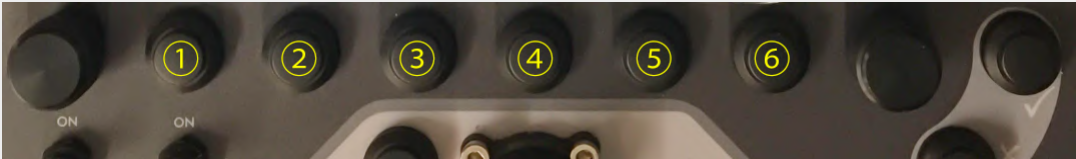

	<p>2. OFF - Set the main camera focus mode to AUTO FOCUS. The camera will autofocus on the scene in front of the camera.</p> <p>FN - Push and hold the switch to the FN position until desired focus is achieved.</p>
20.	<p>Altitude Hold switch. This switch can be used only if an altimeter or DVL is present – see applicable manual for details.</p>
21.	<p>Multifunctional buttons (bottom row):</p> <p>Bottom Row under telemetry screen from left to right:</p>  <p>1-3: No function</p> <p>4: Eject USB – used to eject a USB device connected to the left USB port for storing photos taken by the front camera, or for shutting down the camera control application. See Camera Operations Manual.</p> <p>5: Download Video – used to transfer video recorded by the front camera to an attached USB. See Camera Operations Manual.</p> <p>6: Restart button – will restart telemetry application – allows you to restart the telemetry application displayed on the telemetry screen. While it restarts the telemetry screen will go blank, but video will still appear on the 17” 4K monitor and you can pilot the ROV using the controls as usual.</p>
21.	<p>Multifunctional buttons (row on right side of telemetry screen):</p>
	 <p>7: Currently no function</p> <p>8: Grabber, cutter or brush control (if present)</p> <p>9: Grabber, cutter or brush control (if present)</p> <p>10: Currently no function</p> <p>11: Rapid Set button: only used if ISO/aperture rapid set dial present, see Boxfish Luna Camera Operations Manual.</p> <p>12: Disable Water Sensor: DO NOT use this button unless directed by Boxfish. See Section 19: Troubleshooting.</p> <p>13. Calibrate Compass / Camera Settings.</p> <ul style="list-style-type: none"> ■ See Boxfish Luna Camera Operations Manual for how to change settings on front camera. ■ This button used in conjunction with MODE can



		be used to calibrate the ROV's internal compass - see Section 19: Troubleshooting .
22.	Camera control dial: See Boxfish Luna Camera Operations Manual.	
23.	<p>OK (✓) button:</p> <ol style="list-style-type: none"> Pressing and holding the OK Button for six seconds will initiate a thruster test. See Section 9.4: Test Thrusters. This button is also used for camera settings: to select a value for the currently selected setting. See separate Camera Operations Manual. 	
24.	<p>Cancel (X) button: Pressing and holding the Cancel (X) and Mode buttons together for six seconds will power the ROV OFF remotely. Note: This is equivalent to using the Magnetic Key to power the ROV OFF and ALL functions will be SHUT DOWN.</p> <p>IMPORTANT: The ROV CANNOT be remotely powered on again. The only way to power the ROV on again is to use the magnetic key.</p>	
25.	ZOOM/FN dial: Zooms the camera	
26.	Focus button: Press and hold this button to focus the camera on a certain object until desired focus is achieved. Has the same function as pushing and holding the Focus switch to the FN position.	
27.	Right joystick. In Sea Modes, used to control the ROV forward, back and yaw movements. In ROV Modes, used to control the ROV forward, back and lateral movements.	
28.	PHOTO button: Puts the main camera in photo mode. When a USB is attached to the left USB port, pressing this button will take a photo and save it to the memory stick.	
29.	VIDEO toggle button: Puts the main camera in video mode. Pressing again will start recording to the card in the camera. Pressing for six seconds will restart the camera. See Boxfish Luna Camera Operations Manual.	
30.	(Note this feature is not present on all Lunas ordered before 2023) Aperture/ISO thumbwheel: used in conjunction with the Rapid Set button to rapidly scroll through ISO or aperture values. See Boxfish Luna Camera Operations Manual.	
31.	<p>Stop button (Red). Used to control the following functions:</p> <ol style="list-style-type: none"> Disable the ROV thrusters at the end of a dive. A single press of the STOP button will disable the ROV thrusters. Power off the Control Station - When the Control Station is on, press and hold the Stop button for six seconds to power the Control 	



	Station off. Note: powering off the Control Station will not disable the ROV thrusters.
32.	Metal 1/4" thread mount. Used for the Ninja mount
33.	CLEAN HDMI port: This is a HDMI feed of the video directly from the main camera. This feed is sent to the Ninja Recorder to allow capture of main camera video.
34.	ACCESSORY port: provides power for the Ninja Recorder.
35.	Air ventilation intakes: Air intakes for cooling the Control Station. DO NOT block the vent or the Control Station may overheat and malfunction. Do NOT allow water other foreign objects to enter the vents.
36.	USB left port: Generic USB 3.0 port. Used to attach a USB stick for storing photos/videos recorded by the front camera - see separate Camera Operations Manual. Also used for software/firmware updates and to retrieve log files.
37.	HDMI: Used to send the HDMI feed from the Ninja to the 4K screen. Can also connect the CLEAN HDMI to this port to bypass the Ninja if not using the Ninja.
38.	USB right port: Generic USB 3.0 port.



24 Appendix II: Telemetry screen – more information

Remaining labels not discussed in earlier sections.

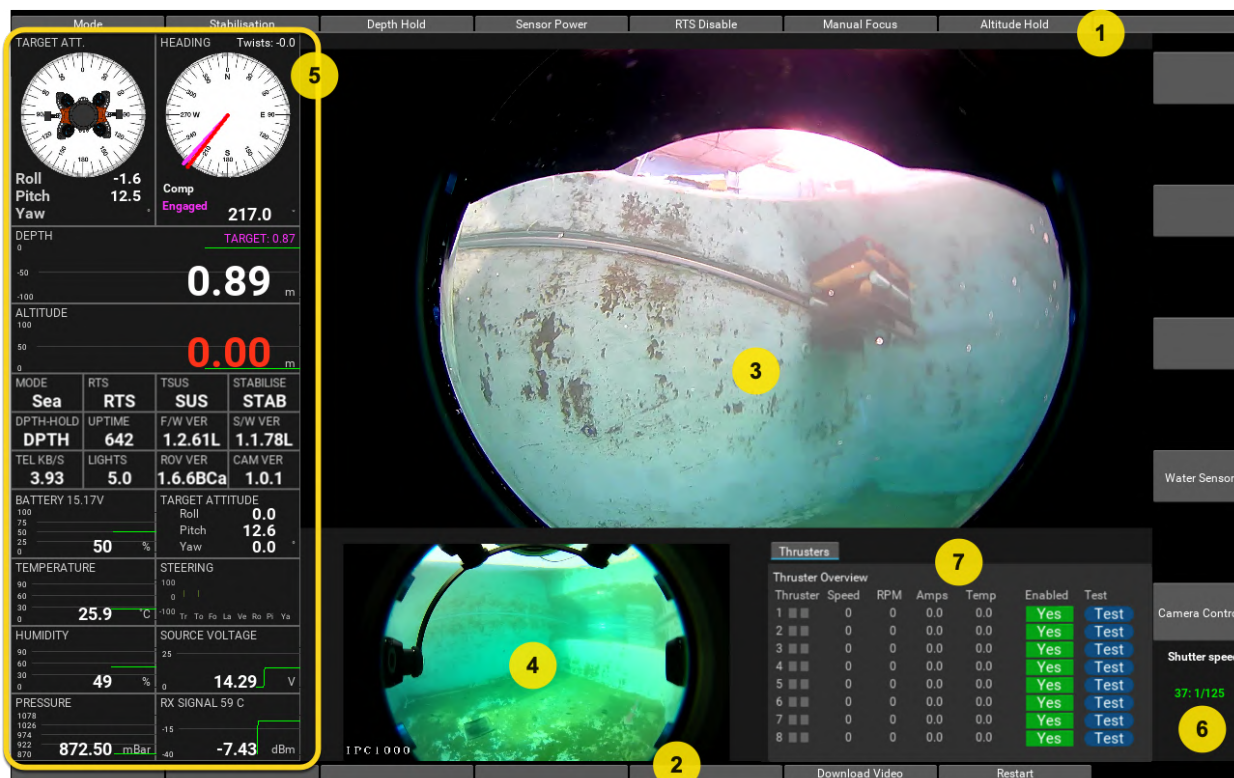

- 5. ALTITUDE:** Altitude from the bottom in metres (will measure altitude only if altimeter accessory is installed and Sensor Power switch is ON), otherwise will display value of 0.00 in red text

MODE: Navigation Mode: Sea Mode, ROV Mode, Sea-Q Mode or ROV-Q Mode

RTS: Will display RTS if Return To Surface Disable switch is OFF

TSUS: If thrusters are enabled, will be ARMD, if they are off will be SUS

STABILISE: Will display STAB if Stabilisation switch is ON

DEPTH: Will display DPTH if Depth Hold switch is ON

F/W VER: Firmware version of Control Station

S/W VER: Software version of Control Station

CAM VER: Software version of computer controlling main front camera

UPTIME: Time since the ROV was powered on. Updates every second. Useful for checking connection between ROV and Control Station

TEL KB/S: Rate of data transfer between ROV and Control Station

ROV VER: Current firmware version of the ROV

TEMPERATURE: Displays current ROV temperature in degrees Celsius and a trend line to give an indication of the temperature over time



	<p>STEERING: Shows input from the sticks but we are developing an improved widget for this</p> <p>HUMIDITY: Displays the current ROV humidity and a trend line to give an indication of the humidity over time</p> <p>SOURCE VOLTAGE: To verify the power source is supplying the necessary voltage (10-28V) to power the Control Station</p> <p>RX SIGNAL: Indicates signal loss over the tether. Will be a negative value indicating signal loss over the fibre connections of the ROV. Is useful to understand if the tether cable is excessively twisted or knotted. When this value approaches -20dBm video feeds and telemetry data will be impacted from appearing on the telemetry screen.</p>
7.	<p>Tabs: Tabs may include Thrusters, USBL or OSD. Thrusters tab is used to turn off/on individual thrusters (see Troubleshooting section). Usage of USBL and OSD tabs will be detailed in separate manuals or instructions.</p>



25 Appendix III: Boxfish Luna ROV – more information

Note: Boxfish Luna products may vary slightly from pictures below, but most components should remain the same.



Front and left side view

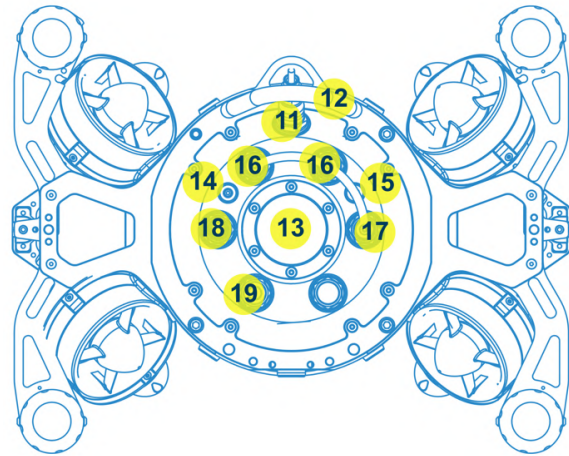

Rear view

1.	Pressure vessel	Pressure-rated ROV body of hard anodised aluminium alloy
2.	Front dome	6" diameter toughened and polished acrylic dome. Contains front camera (Sony a7S III or Sony Alpha 1) and wide-angle navigation camera
3.	Sunshade/bumper	Black Perspex sunshade/bumper.
4.	Frame tube/lifting tube	Carbon-fibre shock-absorbing buoyancy tubes with balancing chambers at each end
5.	Balancing chambers	Balancing chambers for holding ballast washers located at each end of frame tubes
6.	Thrusters	Eight (8) x 3D vectored, Maximum thrust 20kgf (f) / 14kgf (l) / 14kgf (v). Maximum speed 2.1kn (f) / 1.3kn (l) / 1.3kn (v) kn = knots
7.	Lifting eye	For attachment of a lifting or securing cable
8.	Lighting arms and LED lights	Adjustable arms for balanced lighting with minimized backscatter on camera housing
9.	(Optional)	Adjustable LEDs (optional extra)
10.	Rails for optional accessories	Two (2) 8mm diameter x 460mm long parallel rails with a 52mm spacing centre to centre on both the top and bottom of the ROV. Used for mounting accessories such as USBL.



11.	Tether port	For fibre optic tether cable. Provides telemetry, control signals and video to and from the Control Station
12.	Rear bumper	Stainless steel bars integrated into the ROV body for bump protection for sensitive domes and tether areas
13.	Rear dome	Toughened and polished acrylic dome. Contains Status LEDs and rear navigation camera
14.	Off pad (red)	For powering off ROV using magnetic key
15.	On pad (green)	For powering on ROV using magnetic key
16.	Battery charge ports	Positive and negative ports (terminals) for connection to the Battery charger for battery charging.
17.	Battery balance port	Port for connecting the ROV to the battery charger and used to balance each cell to the same voltage
18.	Vacuum port	Port used to apply and release vacuum to the ROV.
19.	Depth sensor	Port containing ROV Depth sensor used to detect depth. DO NOT cover or block depth sensor port or ROV may indicate incorrect depth

25.1 Status indicator LEDs

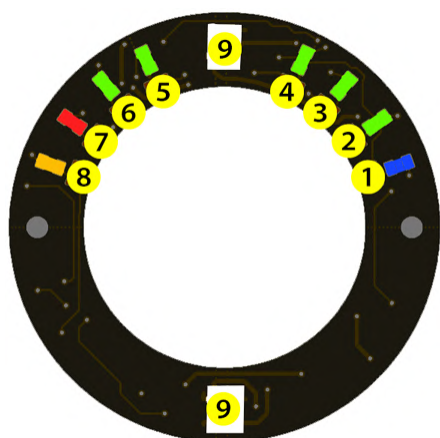

1.	Blue	ROV is powered on
2.	Green	Critical power needed to drive ROV is OK
3.	Green	Power required for main video link is OK
4.	Green	AUX battery power is on
5.	Green	AUX 12V power is on (for optional sensor/device)
6.	Green	AUX 24V power is on (for optional sensor/device)



7.	Red	Thrusters are enabled
8.	Amber	(Blinking) Control system is OK
9.	White	Rear navigation LEDs

- Normal condition of the Status LED's (without optional accessories fitted) is 1, 2, and 3 will be ON and 8 will be flashing.
- LEDs 4, 5 and 6 may be on depending on which accessories you have installed and/or if the Sensor Power switch is set to the ON position on the control station.
- If lights are on and you do not want the rear LED's on, turn the Left Dial on the Control Station so that the lighting intensity falls below 30% and the rear navigation LED's will turn off.

Note: All status indicator LED's will turn off when the ROV is in the water.



26 Document history

Date	Description of changes	Release
20/12/2022	Added: <ul style="list-style-type: none"> ■ More information to Piloting your ROV section, particularly about SEA and ROV piloting modes ■ Instructions to troubleshoot video feed if camera's internal battery goes flat ■ Warning about breaking Ninja power connector ■ Procedure for replacing lights ■ Improved update instructions. 	R8
16/7/2022	Added: <ul style="list-style-type: none"> ■ Warning not to look in fibre ports – risk of eye damage due to lasers ■ Care instructions for domes and tethers to prevent breakages ■ New procedure for updates to Luna ROV, Control Station and camera ■ How to set local timezone on Control Station ■ Change in procedure for initiating compass calibration. 	R7
9/6/2022	Moved all battery-related safety and charging procedures to separate document: Boxfish Battery Charging Manual. Improved WARNING messages. Separated regular maintenance procedures from authorised repair procedures and gave each their own chapter. More Accessory Box additions.	R6
10/5/2022	Improved battery safety information in all relevant chapters.	R5
3/5/2022	Clarified start-up sequence of Luna: Control Station should be started first, then ROV, so that camera controls start correctly, improved instructions in Authorised Maintenance and Repairs section. Added: <ul style="list-style-type: none"> ■ How to set time on Control Station to local time zone 	R4



	<ul style="list-style-type: none"> ■ Updated telemetry screen with new labels and camera software version ■ Boxfish USB stick in Accessories Box and mentioned other items recommended for missions <p>How to reinstall batteries into battery pack.</p>	
2/3/2022	<ul style="list-style-type: none"> ■ New protective solution for shipping ROV cases with cardboard boxes/foam mentioned in 'Boxfish Luna ROV system overview' section ■ Added new items to Accessory Box section. ■ More detail added to shipping and travelling section to help protect all components of the ROV. ■ Added instructions for how to remove ROV tray using new levers in Accessory Box. ■ Renamed 'ROV Maintenance' section to 'Authorised maintenance and repairs' and clarified authorised vs non-authorised repairs. <p>Linked to Boxfish Terms and Conditions from relevant sections: 'Notices' 'Charging the ROV battery' 'Shipping or travelling with ROV' section.</p>	R3
21/12/2021	<ul style="list-style-type: none"> ■ Added requirement to charge ROV for six hours per month during storage periods. ■ New voltages for storing and shipping ROV battery. Also simplified battery charging-related instructions and moved to earlier section. ■ Added instructions for affixing Nauticam N200 dome since it does not fit in ROV's shipping box. ■ Control Station diagrams updated to reflect updated physical layout with additional controls. ■ Telemetry screen diagrams updated with new labels relating to camera control functions. ■ Added more information to Troubleshooting section ■ Moved all maintenance and equipment replacement tasks to ROV Maintenance section. ■ Added section about shipping and travelling with the ROV. <p>Note:</p>	R2



	<ul style="list-style-type: none">■ Camera-related information for both supported front cameras (Sony Alpha 1 and a7S III) moved to separate manual: Boxfish Luna Camera Operations Manual.	
18/7/2021	Branched document from Boxfish ROV Owner's Manual and customised for Boxfish Luna. Initial release.	R1

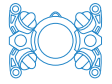



BOXFISH[®]
R E S E A R C H